

SC41X

Computerized Control System for Pattern-sewing Machine (Touching Panel)

Version: 2012-01

Forewords





Thank you for using our Computerized Control System for Special Sewing Machine.

It is appreciated that you do read this manual carefully in order to operate the machine correctly and effectively. If the user operates the machine contrary to regulations herein, thus cause loss to user or third party, we will not take responsibility. Besides, you should keep this manual for future use. For any fault or problem of machine, please ask the professionals or the technicians authorized by us for repair service.











Safety Matters for Attention





1. Signs & Definitions of Safety Marks

This User's Manual and the Safety Marks printed on the products are for you to use this product correctly so as to be away from personal injury. The signs and definitions of Marks are shown in below:

 危険 Danger	The incorrect operation due to negligence will cause the serious personal injury or even death.
 注意 Caution	The incorrect operation due to negligence will cause the personal injury and the damage to mechanism.
	This kind of marks is "Matters for Attention", and the figure inside the triangle is the content for attention. (Exp. The left figure is "Watch Your Hand!")
	This kind of mark is "Forbidden".
	This kind of mark means "Must". The figure in the circle is the contents that have to be done. (Exp. The left figure is "Ground!")

2. Safety Matters for Attention

 危険 Danger	
	For opening the control box, please turn off the power and take away the plug from socket firstly, and then wait for at least 5 minutes before opening the control box. Touching the part with high voltage will cause the personal injury.
 注意 Caution	
Using Environment	
	Try not to use this sewing machine near the sources of strong disturbance like high-frequency welding machine. The source of strong disturbance will affect the normal operation of the sewing machine.
	The voltage fluctuation shall be within $\pm 20\%$ of the rated voltage. The large fluctuation of voltage will affect the normal operations of sewing machine, Therefore a voltage regulator is needed in that situation.
	Working temperature: $5^{\circ}\text{C} \sim 35^{\circ}\text{C}$. The operation of the sewing machine will be affected by environment with temperature beyond the above range.
	Relative Humidity: 45%~85%(No dew inside the machine), or the operation of sewing machine will be affected.
	The supply of compressed gas shall be over the consumption required by the sewing machine. The insufficient supply of compressed gas will lead to the abnormal action of sewing machine.
	In case of thunder, lightning or storm, please turn off the power and pull plug out the socket. Because these will have the influence on the operation of sewing machine
Installation	
	Please ask the trained technicians to install the sewing machine.

	Don't connect machine to power supply until the installation is finished. Otherwise the action of sewing machine may cause personal injury once the start switch is pressed at that situation by mistake.
	When you tilt or erect the head of sewing machine, please use both of your hands in that operation. And never press the sewing machine with strength. If the sewing machine loses its balance, it will fall into floor thus causes the personal injury or mechanical damage.
	Grounding is a must. If the grounding cable is not fixed, it may cause the electric-shock and mis-operation of machine
	The entire cables shall be fixed with a distance at 25mm away from the moving component at least. By the way, don't excessively bend or tightly fixed the cable with nails or clamps, or it may cause the fire or electric shock.
	Please add security cover on the machine head.













Sewing	
	This sewing machine can only be used by the trained staff.
	This sewing machine has no other usages but the sewing.
	When operating the sewing machine, please remember to put on the glasses. Otherwise, the broken needle will cause the personal injury in case the needle is broken.
	At following circumstances, please cut off the power at once so as to avoid the personal injury caused by the mis-operation of start switch: 1. Threading on needles; 2. Replacement of needles; 3. The sewing machine is left unused or beyond supervision
	At working, don't touch or lean anything on the moving components, because both of the above behaviors will cause the personal injury or the damage to the sewing machine.
	During working, if the mis-operation happens or the abnormal noise or smell is found at the sewing machine, user shall cut off the power at once, and then contact the trained technicians or the supplier of that machine for solution.
	For any trouble, please contact the trained technicians or the supplier of that machine.
Maintenance & Inspection	
	Only can the trained technicians perform the repair, maintenance and inspection of this sewing machine.
	For the repair, maintenance and inspection of the electrical component, please contact the professionals at the manufacturer of control system in time.
	At following circumstances, please cut off the power and pull off the plug at once so as to avoid the personal injury caused by the mis-operation of start switch: 1. Repair, adjustment and inspection ; 2. Replacement of the component like curve needle, knife and so on.
	Before the inspection, adjustment or repair of any gas-driven devices, user shall cut off the gas supply till the pressure indicator falls to 0.
	When adjusting the devices needing the power supply and gas supply, users can't be too careful at following the entire Safety Matters for Attention.
	If the sewing machine damages due to the unauthorized modification, our company will not be responsible for it.

Table of Content

1 General Information.....	1
1.1 General Introduction	1
1.2 Functions and Parameters	1
1.3 Matters for Safe Using	2
1.4 The Preventions on Instruction	4
1.5 Standardization.....	5
1.6 Operation Method	5
2 Operation	6
2.1 Basic Operation.....	6
2.2 Instructions on Interface Display Status.....	8
2.2.1 Interface 1 (Main Interface P1: Standard Display Status).....	8
2.2.2 Interface 2 (Status after User Press Menu in Main Interface P1).....	9
2.2.3 Interface 3 (Catalogue Mode in Main Interface P1).....	10
2.3 Instruction of Main Interface P1	11
2.3.1 Pattern Stitch Number Display & Forward/ Backward Moving	12
2.3.2 Speed Adjustment	13
2.3.3 Operation of Pattern Number Hotkey	13
2.3.4 Pattern Display	14
2.3.5 Sewing Fabric Thickness Setting	15
2.4 Main Interface P2.....	16
2.4.1 Winding Mode	17
2.4.2 Up Counter	18
2.5 Load Pattern	19
2.5.1 Direct Load Mode	22
2.5.2 Free Memory	24
2.5.3 Delete Pattern	24
2.5.4 Supported Data Format	25
2.5.5 Display Style of Pattern List	25
2.6 Save Pattern.....	26
2.7 Operation Setting	28
2.7.1 Setting Method	28
2.7.2 Types of Parameter Setting	31
2.7.3 Parameter Encryption.....	31
2.7.4 Recovery and Back-up of Parameter.....	33
2.7.5 Default Parameter Recovery	35
2.7.6 Parameter List	37
2.8 Test Mode.....	47
2.8.1 LCD Test.....	48
2.8.2 Touching Panel Correction.....	48

2.8.3 Input Signal Test	49
2.8.4 Main Shaft Speed Test	49
2.8.5 Output Signal Test.....	50
2.8.6 Continuous Running.....	50
2.8.7 XY Motor Origin Test.....	51
2.8.8 Main Motor Installation Angle Adjustment	51
2.8.9 Network Setting	52
2.8.10 Intermediate Presser Test	52
2.9 Function Setting	53
2.9.1 Data Transfer Mode	54
2.9.2 Formatting Mode.....	56
2.9.3 Pattern Connection Mode.....	57
2.9.4 Version Inquiry Mode	61
2.9.5 Display Setting Mode.....	62
2.9.6 Back-up Recovery Mode.....	65
2.9.7 Default Parameter Mode	65
2.9.8 Pattern Hotkey Management Mode.....	66
2.9.9 Password Mode	67
2.9.10 Parameter Encryption Mode.....	72
2.9.11 Motor Configuration Mode	73
2.9.12 Alarm Record Mode.....	74
2.9.13 Running Records Mode.....	74
2.9.14 Date and Time Setting.....	75
2.9.15 Update Mode	76
2.10 Letter Sewing Edition	76
2.10.1 Parameters of Letter Sewing	77
2.10.2 Adjustment of Letter Sewing Pattern	80
3 Appendix 1	85
3.1 Warning Information List.....	85
3.2 Hint Information List	89
4 Appendix 2.....	94
4.1 Installation Size of Control Box.....	94
4.2 Installation Size of Touching Panel.....	94
4.3 SC41X Diagram and Cable Connection.....	95
4.3.1 SC411 Diagram.....	95
4.3.2 SC412 Diagram.....	96
4.3.3 SC41X Cable Connection	97

1 General Information

1.1 General Introduction

Mitsubishi series computerized control system for industrial sewing machine: 1) Adoption of the world leading AC servo control technology on main shaft motor provides high torque, good efficiency, stable speed and low noise; 2) Diversified design of control panel can meet the special requirement of users on attachment; 3) System adopts German style structure, which offers easy installation and maintenance to users.

1.2 Functions and Parameters

Type of Controller	Mitsubishi Series Computerized Control System for Pattern-sewing Machine			
Sewing area	X(Lateral) Direction		Y(Longitudinal) Direction	
	SC41X:	200	x	100
		250	x	160
		320	x	200
Max. sewing speed	2500rpm (When stitch is below 3mm)			
Stitch length	0.1~12.7mm (Min Resolution: 0.10mm)			
Feed motion of frame	Intermittent feeding (2-shaft driven by stepping motor)			
Needle bar stroke	41.2mm			
Needles	DP×5、DP×17			
Lift of frame	Standard 18mm Max. 22mm (Pneumatic type Max. 25mm)			
Intermediate presser	Stepping Driving (Range: 0~8mm)			
Lift of intermediate presser	20mm			
Shuttle	Double-capacity semi-rotary hook			
Memory of pattern data	Memory/U Disk			
Pause function	Stop the machine during the sewing			
Enlarging / Reducing function	Allows a pattern to be enlarged or reduced on the X axis and Y axis independently when user sews a pattern. Scale : 1% to 400% times (0.1% per step)			
Enlarging / Reducing method	Increasing / decreasing stitch length & Increasing / decreasing stitch number			
Sewing speed limitation	200~2500rpm (100rpm per step)			
Pattern selection function	Pattern No. selection method			
Up counter	No Count/Count on Pattern /Count on Cycle (0~99999)			
Down Counter	No Count/Count on Pattern /Count on Cycle (0~99999)			
Sewing machine motor	Servo Motor			
Needle highest position	After the completion of sewing, the needle can return to its highest position			

stop function	
Power	750W
Voltage of power	AC220± 10% (50~60HZ)

1.3 Matters for Safe Using

● Working Environment

Do not use this control device in the following environments:

- Power Voltage
 - ◆ Voltage fluctuation beyond $\pm 10\%$ of the standard voltage
 - ◆ Capacity of power supply doesn't meet the requirement
- Electrical Disturbance
 - ◆ Beside the wave launcher with strong electrical wave and magnetic field or the high cyclic machine.
- Temperature/ Humidity
 - ◆ Temperature below 0°C or above 35°C .
 - ◆ Outdoors or the area directly shined by sun
 - ◆ Beside stove (heater).
 - ◆ Relating humidity below 45% or above 85% or the area with dew
- Air
 - ◆ Dusty area or area with corrosive gas
 - ◆ Area that is easy to have air explosion or oil explosion
- Vibration
 - ◆ If the location of the sewing machine usually has excessive vibration, please move the control box to other place.。

● Installation

- Control Box
 - ◆ Please install the control box according to the instruction
- Attachments
 - ◆ If other attachments are needed, please turn off the power and pull off the power plug.
- Power Cable
 - ◆ Do not press power cable with force or excessively twist power cable.
 - ◆ The power cables shall be fixed with a distance at 25mm away from the rotating component at least.
 - ◆ Before powering the control box, user shall carefully check the voltage of power supply and position of power input on control box. If the power transformer is used, user should also check it before powering the machine. At this moment, the power switch of sewing machine must be set as "Off".
- Grounding
 - ◆ In order to avoid the noise disturbance and shock caused by electrical leakage, user should ground the grounding cable.
- Attachments
 - ◆ If the electrical attachments are needed, please connect them to the proper

positions.

■ Disassemble

- ◆ When removing the control box, user should turn off the power and pull off the power plug.
- ◆ At pulling off the power plug, user should hold the plug and remove it, instead of pulling the power cable only.
- ◆ The control box contains the dangerous high voltage power. For opening the control box, please turn off the power and take away the plug from socket firstly, and then wait for at least 5 minutes before opening the control box.

● **Maintenance, Inspection and Repair**

- Only can the trained technicians perform the repair and maintenance of this machine.
- When replacing the needles and shuttles, user has to turn off the power.
- Please use the spare parts from the authorized manufacturers

● **Others**

- Do not touch the rotating or moving part of the machine, especially the needle and belt, when the machine is working. User should also keep his/her hair away from those moving parts, so as to avoid the danger.
- Do not drop the control device on the floor, nor insert any stuff into the slots on the control box.
- Do not run the machine without the cover shells
- If this control device is damaged or unable to work normally, please ask the technicians to adjust or repair it. Do not run the machine when the problem is not solved.
- Please do not change or modify the control device without authorization.

● **Abandonment**

- Dispose it as common industrial trash.

● **Warning and Danger**

- The mistake operation may cause danger. For the serious level, please refer to the figure at below:

 警告	错误的行动可能会发生重伤或死亡。	 注意	错误的行动可能会发生伤害或房屋或财产的损害。
---	------------------	---	------------------------

- The meaning of the figure are shown at below:

	请遵照指示内容作业。		注意高压电 (电击) 的危险。
	注意高温。		务必接上接地线。
	绝对不要执行。		

1.4 The Preventions on Instruction

 **警告** **Warning**

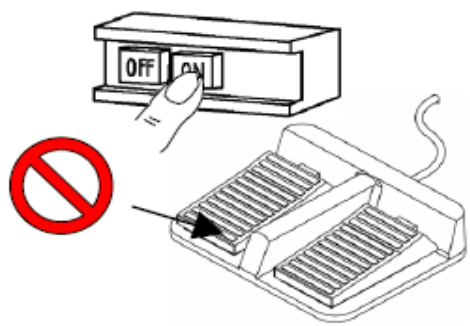
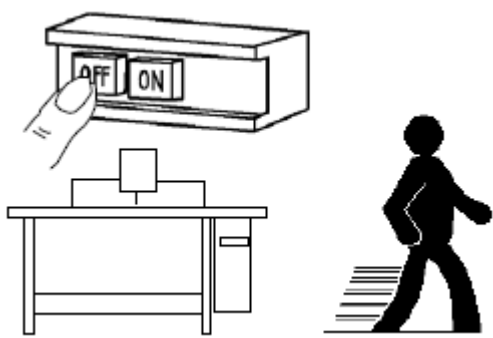
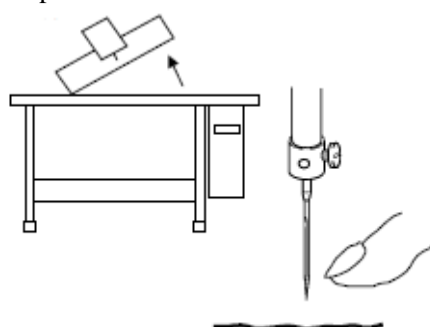
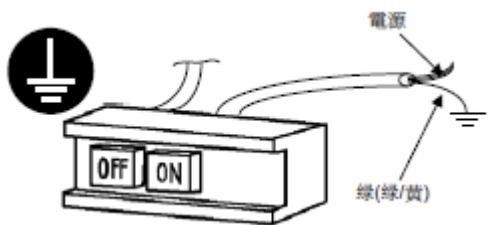
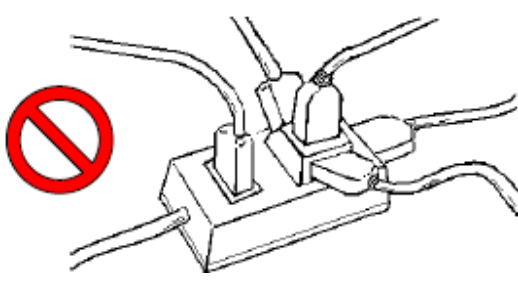
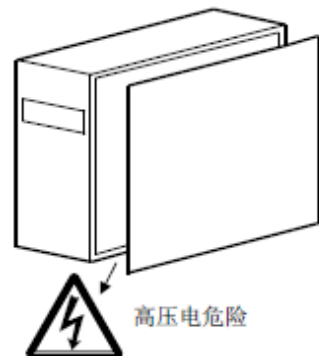
<p>1. When you press the switch [ON], please do not step the pedal.</p> 	<p>2. When you leave the machine, please turn it off.</p> 
<p>3. If user needs tilt the head or replace the needle or thread the upper thread, please turn off the power</p> 	<p>4. Grounding the machine with ground cable</p> 
<p>5. Do not use the household terminal block to let machines to share one power supply</p> 	<p>6. For opening the control box, please turn off the power and take away the plug from socket firstly, and then wait for at least 5 minutes before opening the control box.</p> 
<p>7. After replacing the motor, user has to adjust the main motor installation angle according to this manual.</p>	
<p>8. Please keep it away from the machine creating the high cyclic disturbance</p>	<p>9. If user needs the external signal socket to connect the attachments, the connecting</p>

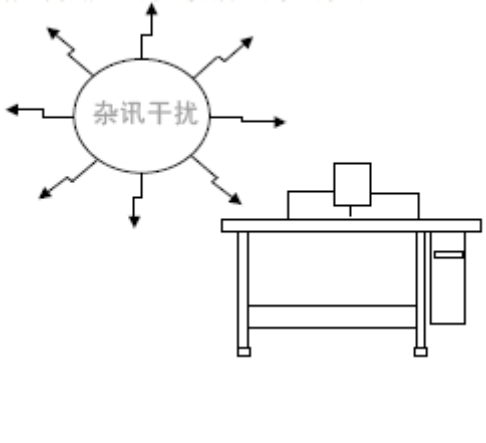
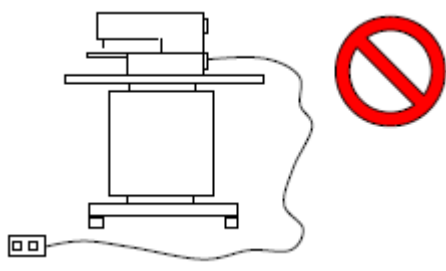
	<p>wire shall be as short as possible. The long cable may cause the wrong operation. And the connection cable shall be the isolated cable</p> 
<p>10、 If the fuse is burnt, please solve the problem before replacing a new one with same capacity.</p>	

1.5 Standardization

The function keys use the general figures with the meaning agreed in the trade. The figures are the internationalized language that users in each country can recognize it.

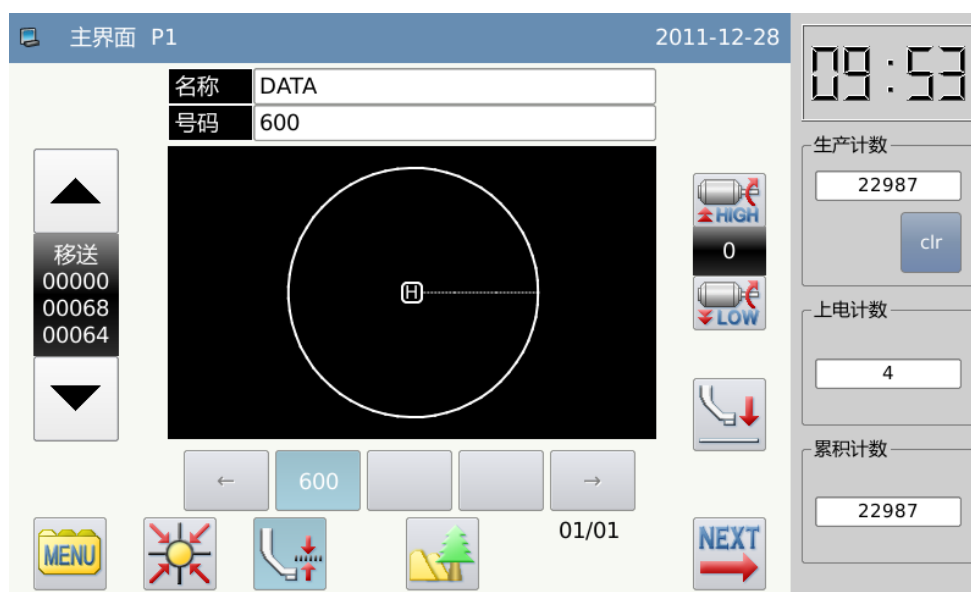

1.6 Operation Method

The Mitsubishi type touching panel adopts the advanced touching operation technology, whose friendly interface and easy control bring the revolutionary changes to the daily usage of the users. For performing the relating operations, user can use his fingers or other objects to touch the screen.



Don't use the sharp object to touch the screen so as to avoid causing the permanent damage to the touching panel.

2 Operation

2.1 Basic Operation

1、 Turn on Power Switch

After user turns on the power, the main interface P1 will be displayed.

[Note]: If the memory of system contains no pattern when user turns on the power, the system will display “Cannot Find Pattern in Memory”. At this moment, user needs press



to close the hint and shift to the main interface.

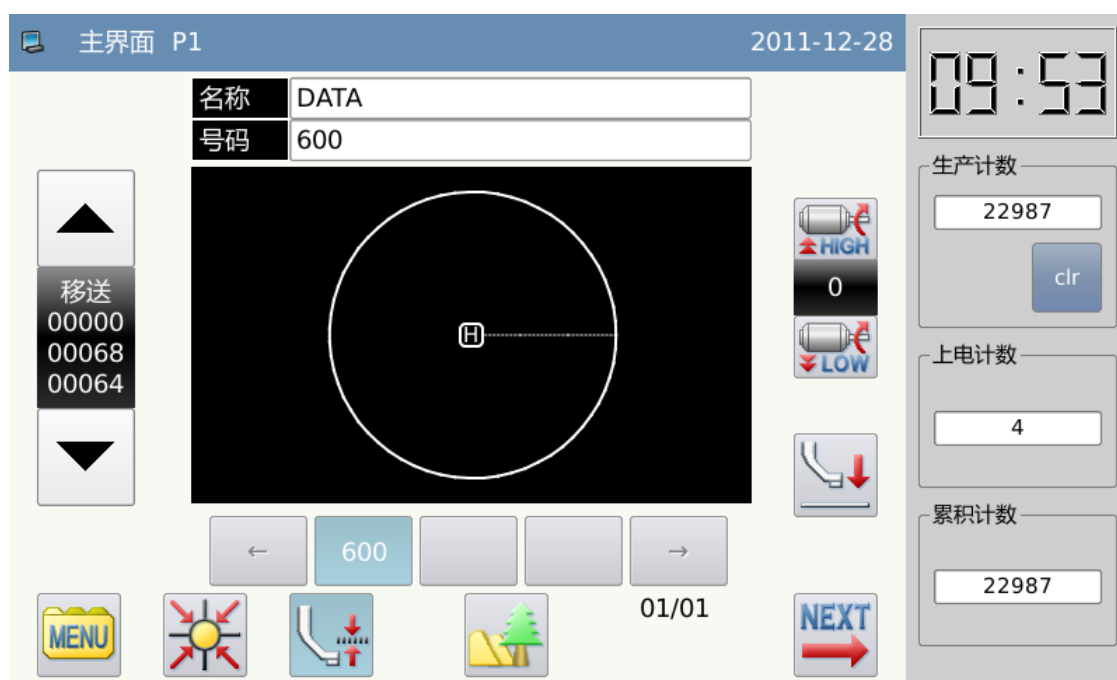

2、 Pattern for Sewing

Display the selected pattern in the current interface. If user wants to change the pattern, he should refer to section [2.5 Load Pattern].

3、 Start Sewing

① Before the actual sewing, user need confirm the settings of the sewing conditions again, especially the setting of the speed (Range: 0~9).

② The speed of sewing machine is determined by the speed value and stitch interval. The speed value will determine the max speed of sewing machine, while the stitch interval will limit the speed of sewing machine.

[Note]: Do not change the speed value during the sewing, except the condition of pause, otherwise it may cause influence on the thread-withdrawing condition.

③ Put the sewing material to the pointed position, step the frame switch (black one) to

lower the frame and step the running switch (grey one) to start the actual sewing. Once the sewing starts, user will not need to continue stepping on the running switch. When the sewing machine finishes the work, the frame will go up automatically.

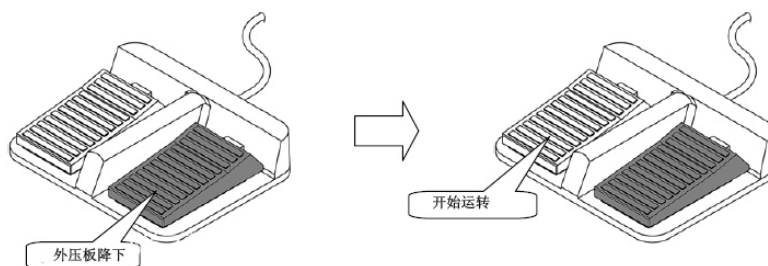

4、Pause

If user wants to stop the machine during the sewing, please press the emergency stop button on the head (Please refer to the following figure for details). After user presses that key, the sewing machine will stop at the upper position (default setting) and enter the pause status. For releasing the pause status, please press that emergency stop button again. Then user can continue performing the following operation.

- ① Step on the pedal to continue the sewing
- ② Press Forward Moving/ Backward Moving to move to the sewing start position
- ③ Step the frame switch to lift frame.
- ④ Change the speed value of sewing machine
- ⑤ Move the intermediate presser

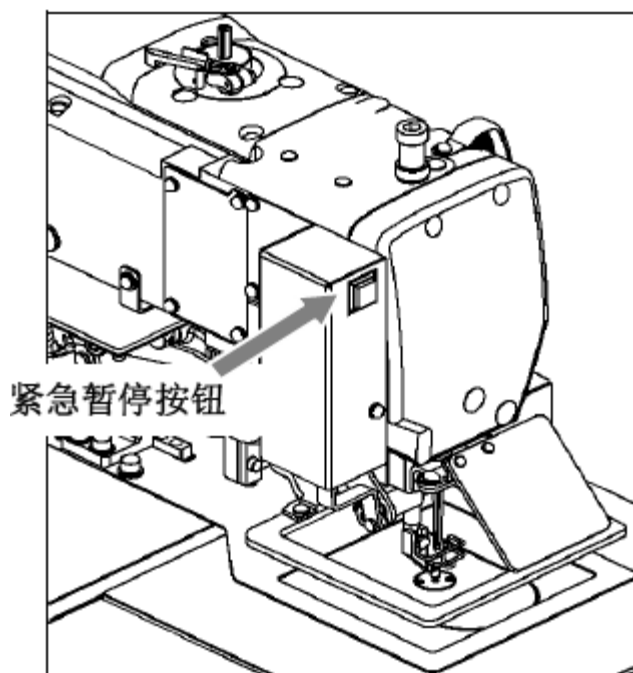

5、Method for Mending the Sewing

User can use the pause function to perform the mending sewing. If user presses emergency stop key at thread-breakage, the needle will stop at the upper position. Press backward moving key to move the frame to the position that is two or three-stitches before the thread-breakage point, thread the thread and step the running switch. After that, user can continue the sewing.



注意 在穿针线时，绝对不可用脚去踩踏运转开关，会使缝纫机运转，是很危险的，所以在穿针线时务必把脚移开运转开关。

2.2 Instructions on Interface Display Status

2.2.1 Interface 1 (Main Interface P1: Standard Display Status)

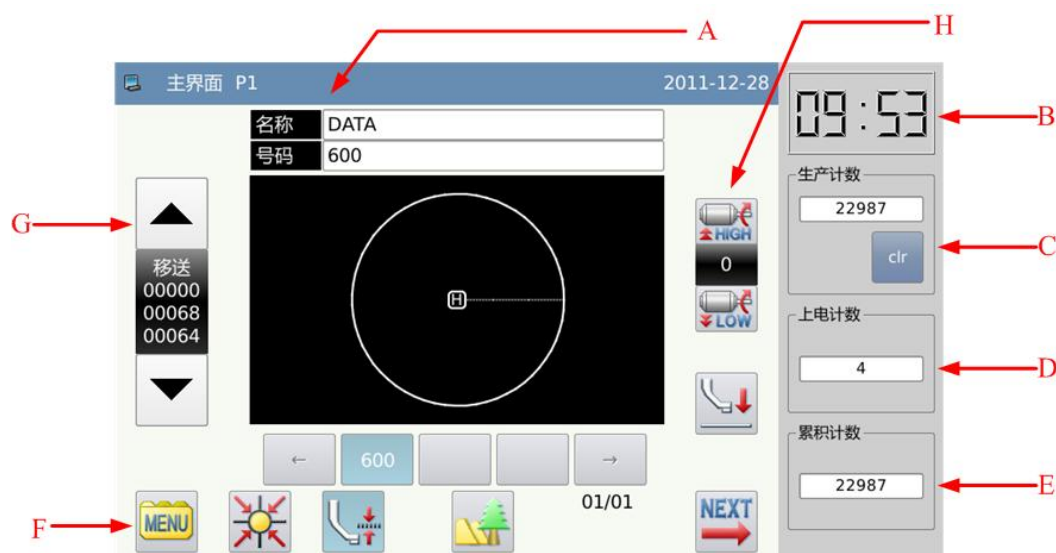

Functions:

No.	Functions	Content
A	Title Bar	The left part is the title of this interface, while the right part is the date in system When user presses a button, the left part of the title will be refreshed to the function description of that button (Please refer to Interface 2).
B	Clock	The displayed content is the current time (For setting the clock, please refer to [2.9.14 Data and Time Setting Mode]).
C	Product Counter	Record the accumulated sewing number. User can press  to clear the content and start counting again.
D	Power-on Counter	Record the sewing numbers after power-on. User can clear the content by turning off the machine. This counter will be refreshed at power-on in each time

E	Accumulation Counter	Record the accumulated sewing numbers during the running. (For clearing that value, please refer to [2.9.13 Running Record Mode]).
F	Menu	Press that key to perform the corresponding functions (Mostly, the system will have access to the corresponding function interface).
G&H	Buttons Enabling to Perform Continuous Functions	Press those keys to perform the corresponding functions. Holding the button means to perform the order continuously.

[Note] The comparison among Product Counter, Power-on Counter and Accumulation Counter:

- **Product Counter is to record the accumulated sewing number. But user can use  to clear the value and restart counting;**
- **Power-on Counter is to count number from 0 after the machine is turned on;**
- **Accumulation Counter is to record the accumulated sewing number, which can't be cleared in the current interface**

2.2.2 Interface 2 (Status after User Press Menu in Main Interface P1)



Functions:

No.	Description
A	The left part of title bar is the functional description of that button. When user removes finger from the button B, the left part will be refreshed to the interface title.
B	Press it to refresh the interface title. When user removes finger from the button, the corresponding function will be performed.

2.2.3 Interface 3 (Catalogue Mode in Main Interface P1)

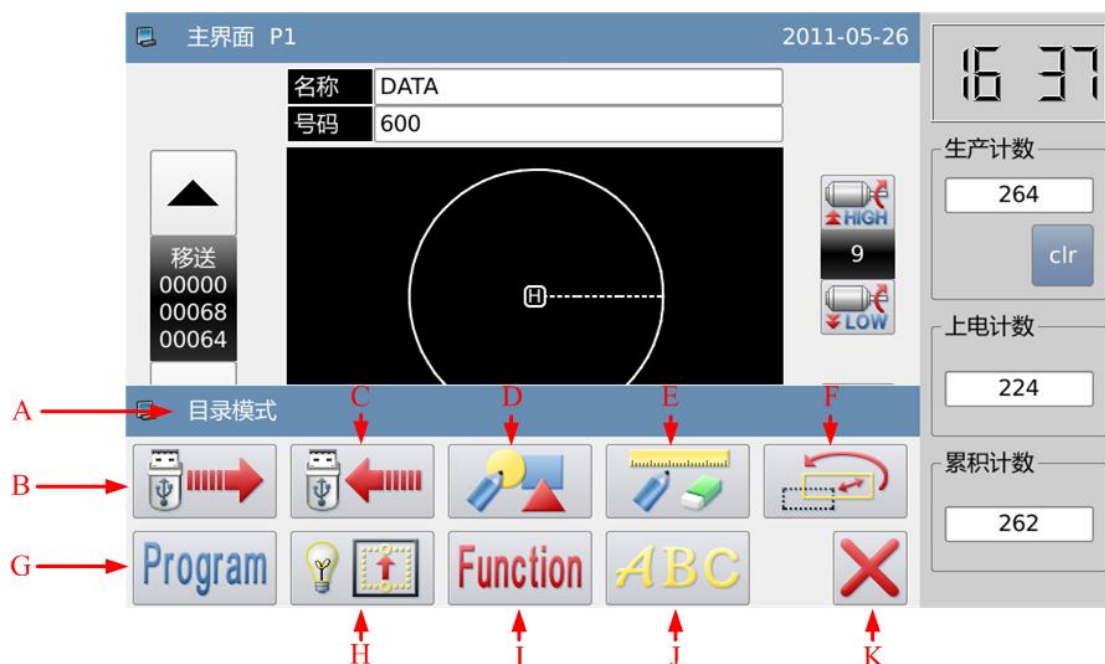



Functions:

No.	Function	内容
A	MENU Function Interface Title	The displayed content is the interface title of the MENU. When user press the button, the displayed content in the title bar will become the functional description of the corresponding key
B	Load Pattern (Load Pattern Data)	Load a pattern from memory or U disk for sewing.
C	Save Pattern (Save Pattern Data)	Save the pattern to memory or U disk
D	Edit Pattern (Pattern Design Mode)	Edit the pattern
E	Modify Pattern (Modification Mode)	Modify the pattern
F	Data Transfer (Data Transfer Mode)	Transfer the data
G	Operation Setting	Set the parameters
H	Test Mode	Test the external devices, LCD screen and so on
I	Function Setting	Perform the function operations
J	Letter Sewing Edition	Perform letter sewing edition [Note]: User can close letter sewing edition via Parameter "Special" -> "Enable Letter Sewing". The figure will not be displayed when the function is deactivated.
K	Quit	Quit the current interface, and return to the upper interface.

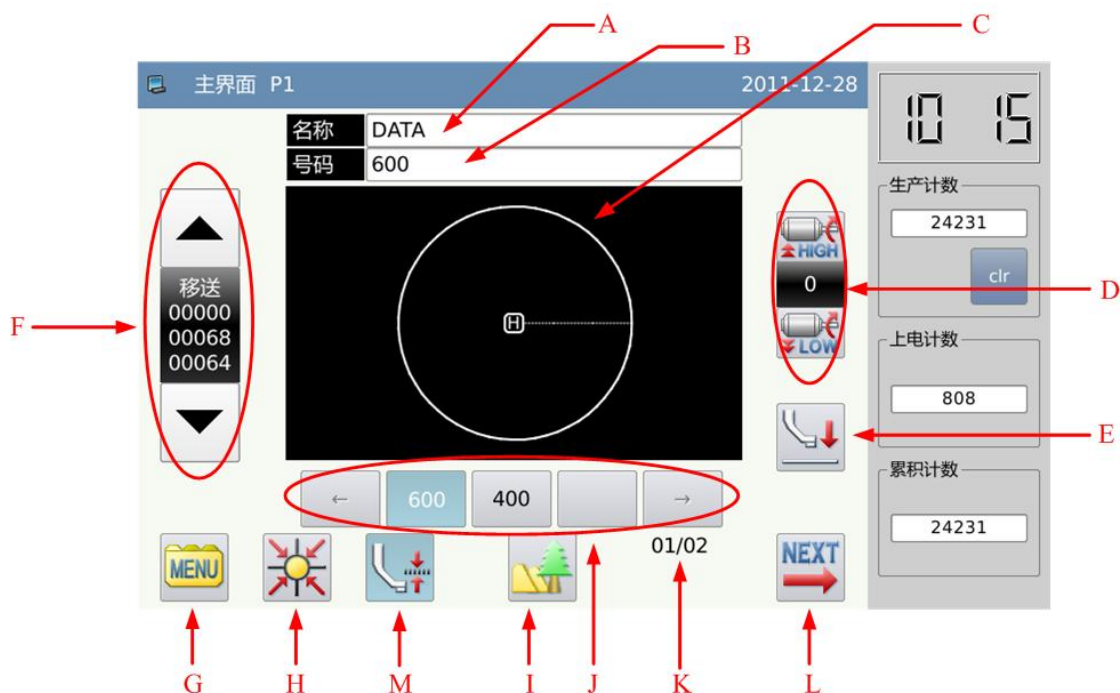
2.3 Instruction of Main Interface P1



Functions:

No.	Functions	Content
A	Pattern Name	Display the name of current pattern
B	Pattern Number	Display the number of the current pattern
C	Pattern Shape	Display the shape of the current pattern [Note]:  is the position of origin.
D	Speed Adjustment Area	Adjust and display the sewing speed of current pattern
E	Move Intermediate Presser	Press the key to move the intermediate presser in the pointed direction.  : Press it to lift the intermediate presser  : Press it to drop the intermediate presser
F	Pattern Stitch Number Display Area and Forward/Backward Moving Keys	Display the stitch number and perform the trial sewing
G	MENU	Display the catalogue (refer to [2.2.2 Interface 2])
H	Back to Origin	Press it to return to origin
I	Pattern Information Display	Display the shape and detailed information of the current pattern
J	Pattern Number Hot key	Display the recently used pattern numbers, at most 20 numbers can be saved. Pressing the pattern number will activate that pattern for sewing. [Note]: In combined sewing pattern mode, the displayed content is the sub-pattern number and the C pattern number
K	Pattern Number Hotkey Information	Display the index number of the current hotkey (Displayed in white figure on blue background) /the total number

L	Display Next Standard Interface	Have access to Main Interface P2
M	Sewing Fabric Thickness Setting	Set the min height of the intermediate presser [Note]: Unavailable in E Type Machine.

2.3.1 Pattern Stitch Number Display & Forward/ Backward Moving

Functions:

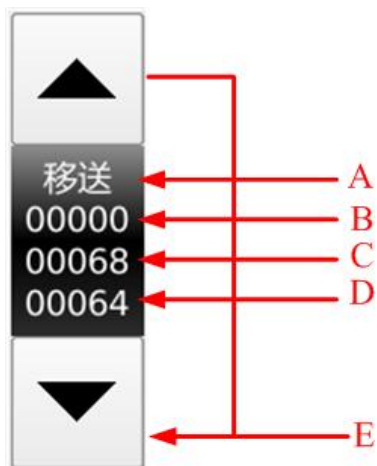

No.	Descriptions
A	Display the current frame sewing data type. (Sewing "SEW", Feed "FEED", Sub-origin "2HP", Upper Stop "USTP", Down Stop "DSTP", Thread-trimming "TRIM", Feed Speed "FEDS", Restart "ASRT", Board Heavy "HEVI", Fabric Thick "ATUM", Jump Sewing "BAT", Function 1 "FUN1"~Function 7 "FUN7", Reverse Presser Feet "REPF", End "END")
B	The stitch number at current position
C	Total stitch number of the current pattern (Including Feed, Thread-trimming, End and Code)
D	Total sewing stitch number of current pattern (Excluding Feed, Thread-trimming, End and Code)
E	Test Pattern(Forward / Backward). 1、 After it returns origin, X-Y (frame) will move forward on the pattern when user press the "Upper". Release the key to stop moving. Holding the "Down", the X-Y (frame) will move backward. Release the key to stop moving 2、 If the frame is at down position and the pattern is right, user can step the pedal to have machine to start sewing.

2.3.2 Speed Adjustment

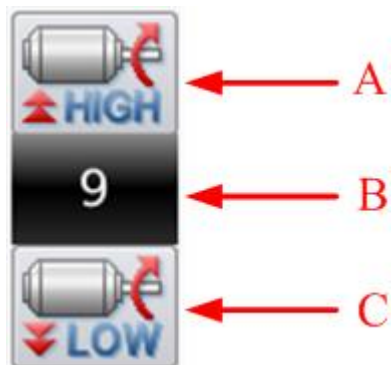

Functions:

No	Description
A	Acceleration
B	Current sewing speed (0~9)。
C	Deceleration

2.3.3 Operation of Pattern Number Hotkey

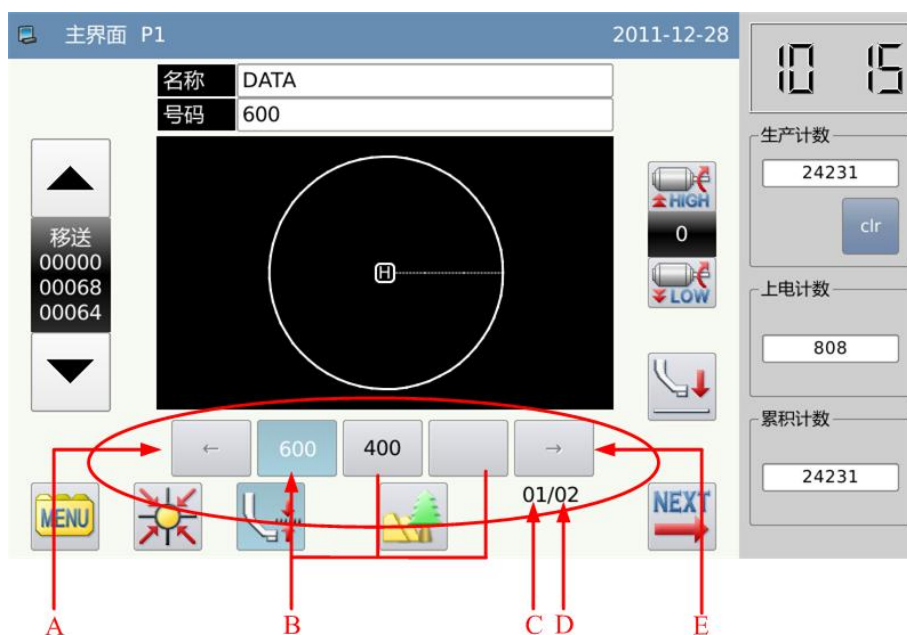

Function:

No.	Description
A	Look up forwardly.
B	Pattern number hotkey (Current pattern: Displayed in white figure on blue background), select other number to shift the pattern.
C	Index number of current pattern number in the hotkey list.
D	Total number of the pattern number within the hotkey list (At most, 20 pattern numbers are contained)
E	Look up backwardly.

Example:

As shown in the above figure, 2 pattern numbers are in the hotkey list. The current pattern number is 600. If we select the No.400 pattern, the current pattern will be shifted to the No.400 pattern. The display is as shown in below:

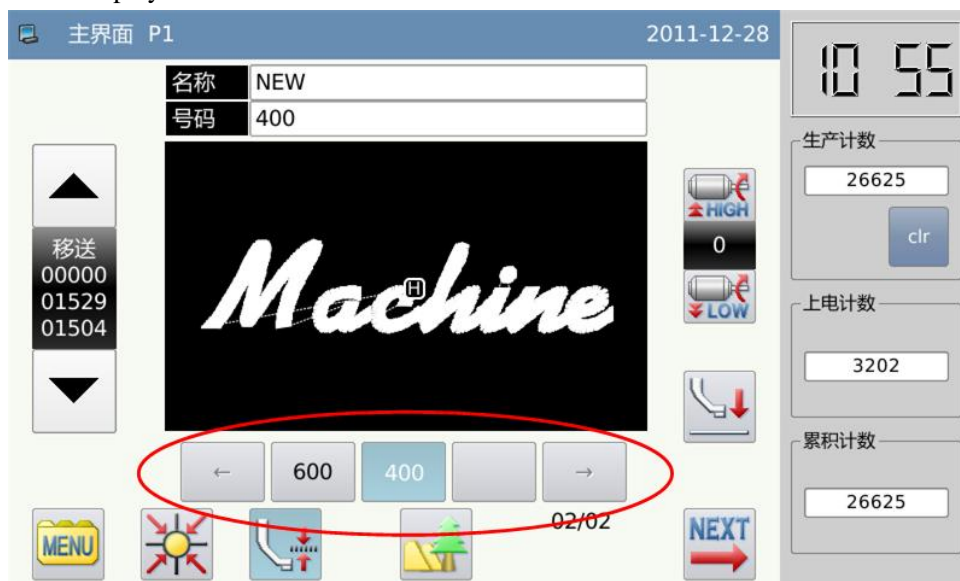

2.3.4 Pattern Display

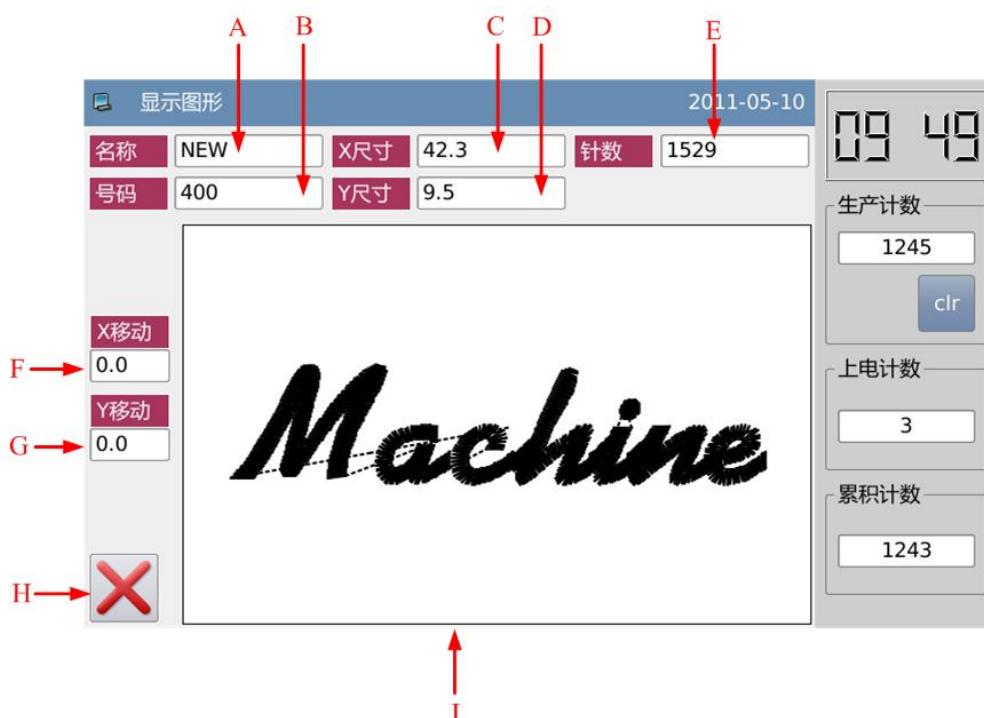

Function:

No.	Description
A	Pattern Name

B	Pattern Number
C	Size of Pattern in X Direction
D	Size of Pattern in X Direction
E	Display Total Stitch Number of Pattern (Including, Feed, Trimming, End, Code and so on).
F	Origin Correction in X Direction
G	Origin Correction in Y Direction
H	Quit current interface and return to the previous interface.
I	Pattern Display.

2.3.5 Sewing Fabric Thickness Setting

The lowest position of the intermediate presser is changeable. If the lowest position of intermediate presser in the default setting is lower than the thickness of the used fabric, user will be able to use this function to change it.

[Note]: If user has access to this interface when the intermediate presser is at down position, the system will hint “Lift Intermediate Presser”.



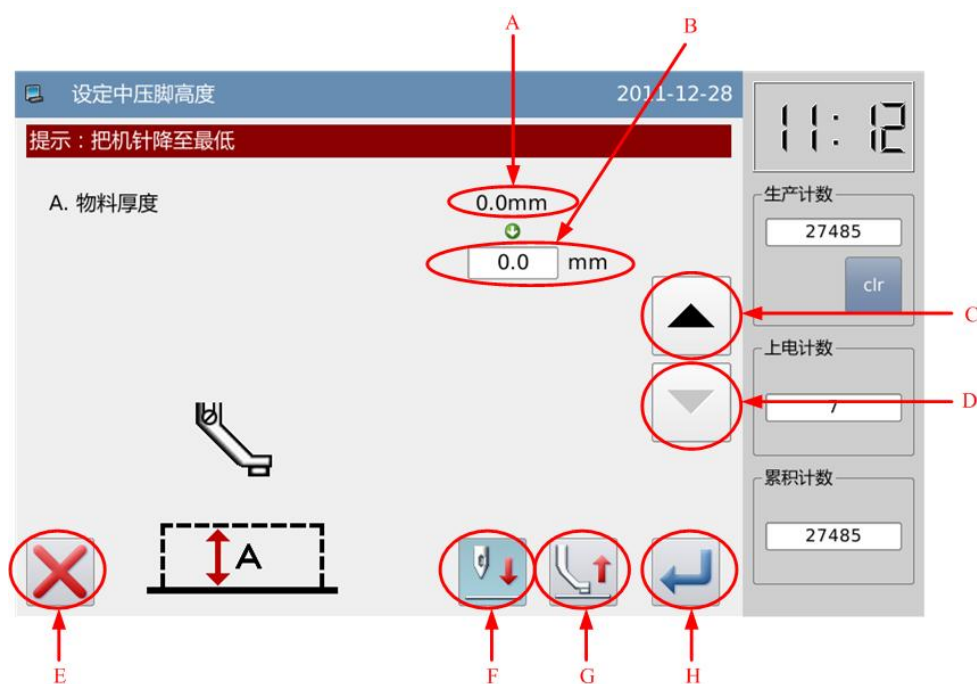

[Note]: After having access to the interface for setting the fabric thickness: only when the intermediate presser goes down, can user set this parameter.

[Note]: The range of this parameter is 0.0~8.0mm.



Functions:

No.	Description
A	Current Height of Intermediate Presser
B	Target Height of Intermediate Presser

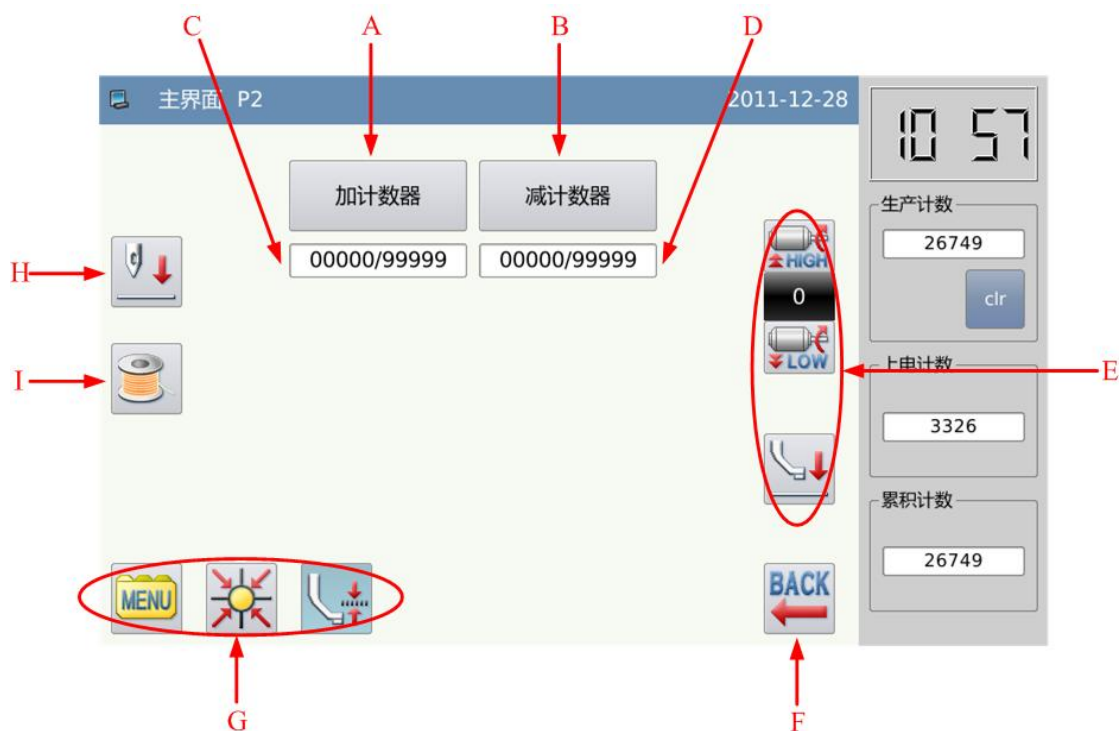

C	Increase Height The intermediate presser goes up for 0.2mm at each pressing
D	Decrease Height The intermediate presser goes down for 0.2mm at each pressing
E	Quit the current interface and return to the previous interface.
F	Move needle vertically.  : Needle down  : Needle up
G	Press it to move the intermediate presser in the arrow direction  : Intermediate presser up  : Intermediate presser down
H	Save and Quit

2.4 Main Interface P2



Functions:

No.	Functions	Content
A	Up Counter	Have access to interface for setting up counter
B	Down Counter	Have access to interface for setting down counter
C	Up Counter Value	Display the current value/ set value of up counter

D	Down Counter Value	Display the current value/ set value of down counter
E & G	Same as that in main interface P1	For the functions, please refer to the content in Main Interface P1
F	Return	Return to main interface P1
H	Needle Move	Move needle vertically.  : Needle up  : Needle down
I	Winding	Have access to winding mode

2.4.1 Winding Mode

For winding, user has to activate this interface (Press  in main interface P2 to lower the intermediate presser). Step the frame switch to lower the frame and then step the running switch to run the sewing machine in the set speed. The X & Y axis will not move. When user releases the running switch, the sewing machine will stop at the upper stop position.

[Note]: The winding action is determined by the parameter “Winding” in the Operation Setting Mode. (Please refer to [2.7.6 Parameter List])



Functions:

No.	Description
A	Set Speed of Winding [Note]: Determined by Parameter “Winding” -> “Winding Speed Setting”
B	Actual Speed of Winding
C	Winding Operation Method [Note]: Determined by Parameter “Winding” -> “Winding Stop Method”.
D	Set Time of Timing Winding

	[Note]: Determined by Parameter “Winding” -> “Timing Stop of Winding”
E	If the operation method of winding is the timing winding, this place will display the time leftover.
F	Quit winding mode and return to the previous interface

2.4.2 Up Counter

In main interface P2, press  to have access to the interface for setting the up counter.

[Note]: The counting method of the up/down counter is determined by the parameter “Counter” in Operation Setting Mode (Please refer to [2.7.6 Parameter List]).

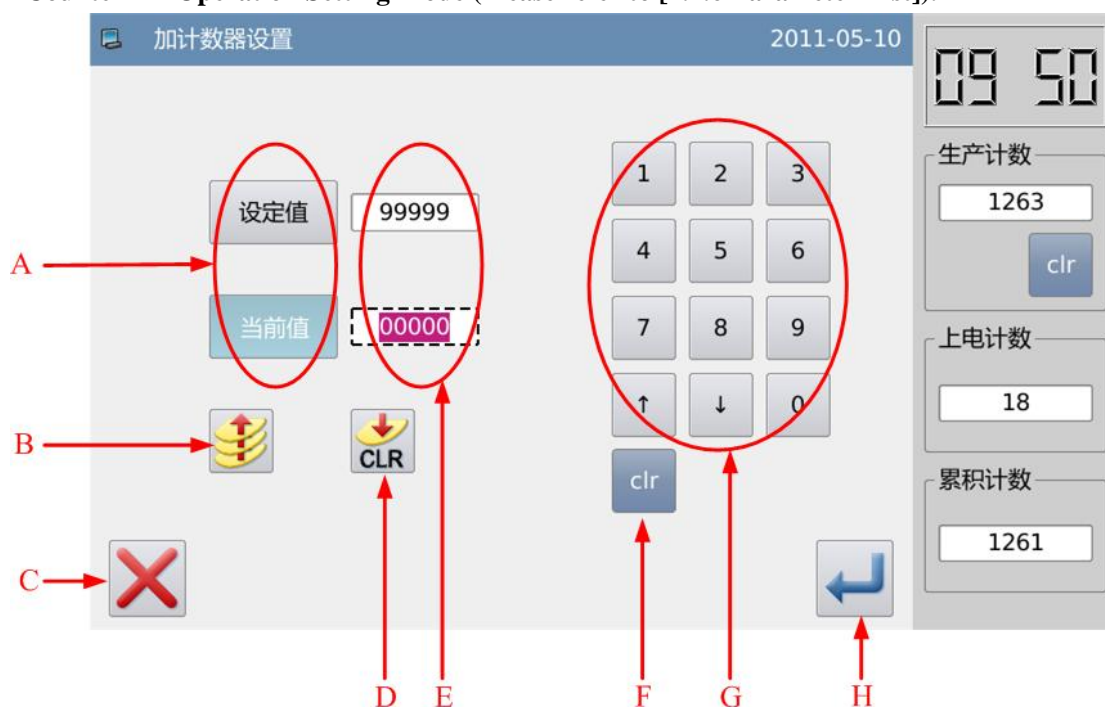

Functions:

No.	Content
A	Shift the input between the set value and the current value (The button in shadow is the selected one).
B	Up Counter Switch (This button will be effective when it is in blue background).
C	Quit counter setting mode and return to previous interface.
D	Clear current value.
E	Display the set value and current value (User can input the value in the spot line frame)
F	Clear the value inputted currently
G	Number keyboard, used to input set value and current value

H	Confirm the setting
---	---------------------



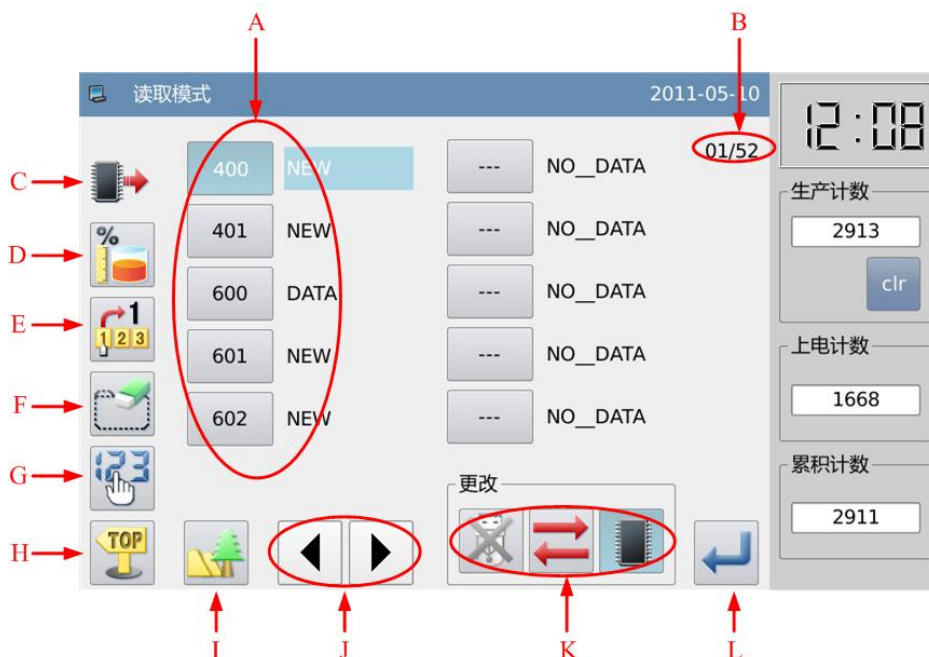

[Note]: The operation of the down counter is same to that of the up counter, the only difference between them is the down counter switch (📉).

2.5 Load Pattern





Functions:

No.	Functions	Content
A	Pattern List	Display the list of the saved pattern (Both number and name will be displayed). [Note 1]: If user selects pattern in VDT format, system will ask user to transfer the pattern format. [Note 2]: If the stitch number of the selected pattern is over range or the data is damaged, the system will hint that the pattern is unable to be selected.
B	Page	Display current page number/ total page number
C	Memory / U Disk Object Display	: Memory Pattern List. : U Disk Pattern List [Note]: The default setting is to load pattern from memory
D	Free Memory	Display the total number of the patterns saved in memory
E	Direct Loading	Input the pattern number to load that pattern directly.
F	Delete Pattern	Delete the selected pattern. [Note]: The currently sewn pattern cannot be deleted.
G	Sequencing	Sequence the patterns according to their modification time or the number.

H	Return to Main Interface	Return to main interface directly
I	Pattern Display	Same as the function key in main interface P1.
J	Page Key	Search the pattern in the next pages or the previous pages
K	Select Memory/ U Disk	<p>Load pattern from memory or U disk</p> <p> : Activate the Memory Load Mode: At this moment, user cannot load pattern from U disk.</p> <p> : Deactivate the Memory Load Mode: At this moment, user can load pattern from U disk.</p> <p> : Activate the U Disk Load Mode: At this moment, user can not load pattern from memory.</p> <p> : Deactivate the U Disk Load Mode: At this moment, user can load pattern from memory.</p> <p> : Shift between U Disk and Memory</p>
L	Enter	Confirm the operation. After the operation, the sewing pattern will turn to the newly selected pattern.

Operation:

1、进入花样读取界面

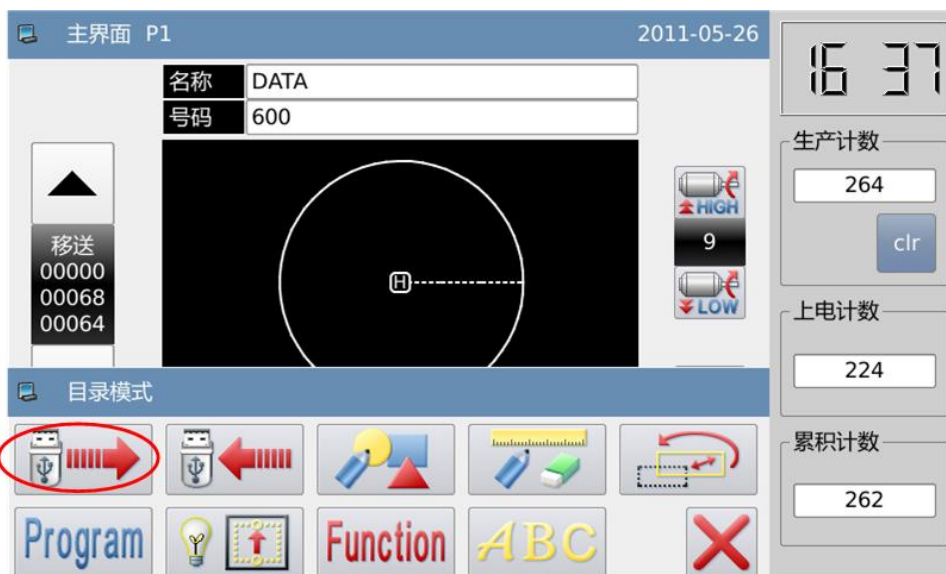

In main interface P1 (or P2), press  to activate the catalogue mode, and then press .

[Note]: If the icon is not at the origin, the system will be unable to load pattern. Therefore, please perform the operation for returning to origin firstly.



2、Select the Object for Loading (Memory/ U Disk)



The default setting in this interface is the Memory Load Mode (you can see  at the upper left of the screen). You can press  to shift to U Disk Load Mode, which is shown at below:

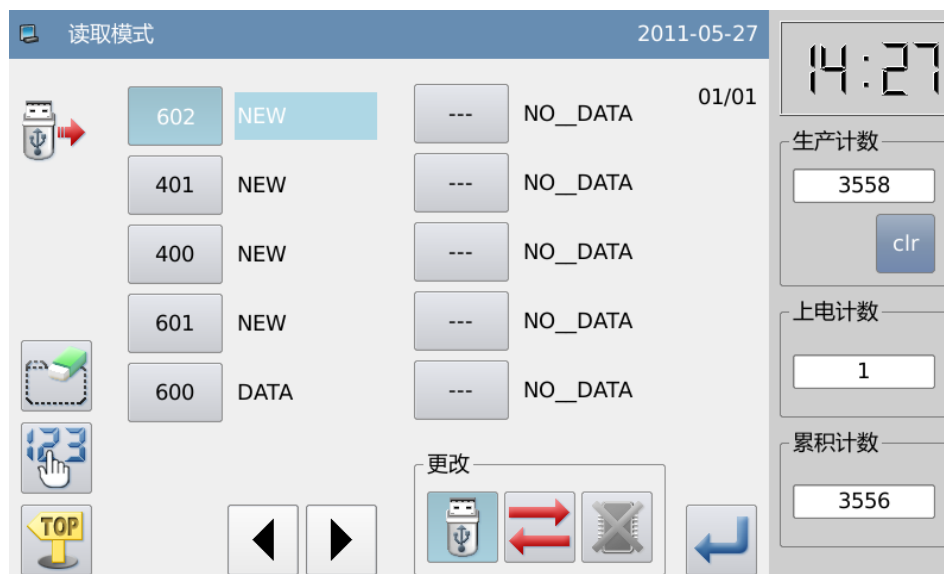

[Note]: If user performs the above operation without inserting the U disk, the system will display “U Disk Is Pulled Out”.





[Note]: If user inserts the U disk in the current interface, the system will need 5s to identify the U disk. After the identification, user can press  to enter the U Disk Load Mode. As long as the U disk is not pulled out, the system will not need to identify the U disk again when user has access to the U Disk Load Mode again.

3、 Select and Confirm Pattern Number

Select the pattern for sewing and then press . After the selection, the system will return to the main interface directly.

[Note]: If the pattern with the same exists in the memory when user loads pattern from U disk, the system will display “Replace Pattern in Memory”. At this moment, user needs follow the pointed instruction.

4、 Other Operations

If there are many patterns, user can use   to turn the pages and press  to 可以 view the pattern more lively. If user knows the pattern number, he will be able to use the  to load the pattern directly.

2.5.1 Direct Load Mode

1、 Select Direct Load Mode

Press  in pattern loading interface to have access to the Direct Load Mode

[Note]: To load pattern by directly pointing the pattern number, user has to have access to memory load mode.



2、 Point Number 1

(Example, load pattern No.612)

- ① Input “6”.
- ② The 10 button at below will display the patterns saved in the memory whose first number is 6.

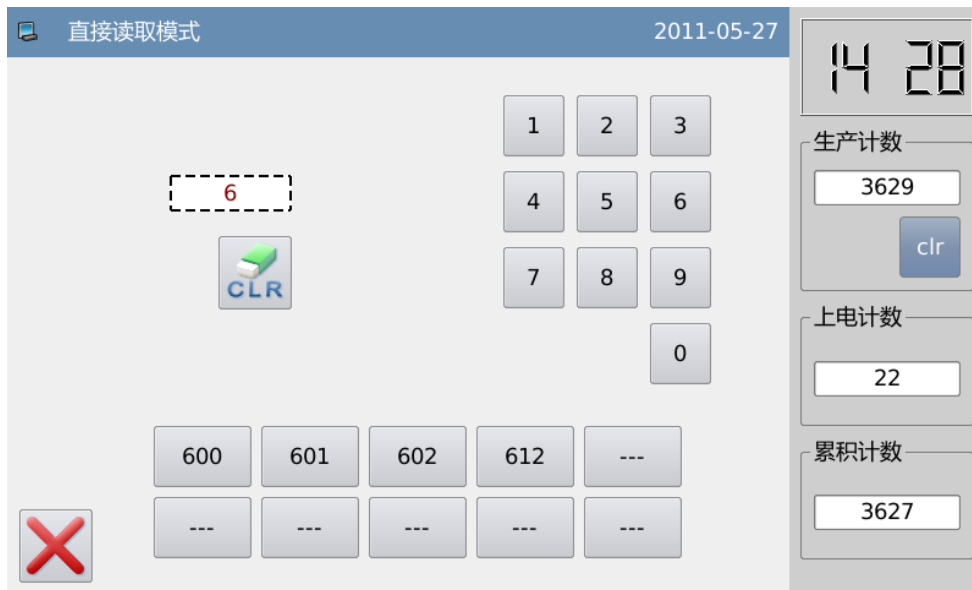

2、Point Number 2

- ① Then input "1".
- ② The buttons at below will display the patterns within the memory whose number begin with "61".

③ Press  to clear the inputted number and re-input them.

- ④ At this moment, the "612" will be displayed at the button below. At this moment, press



to activate the pattern No.612.

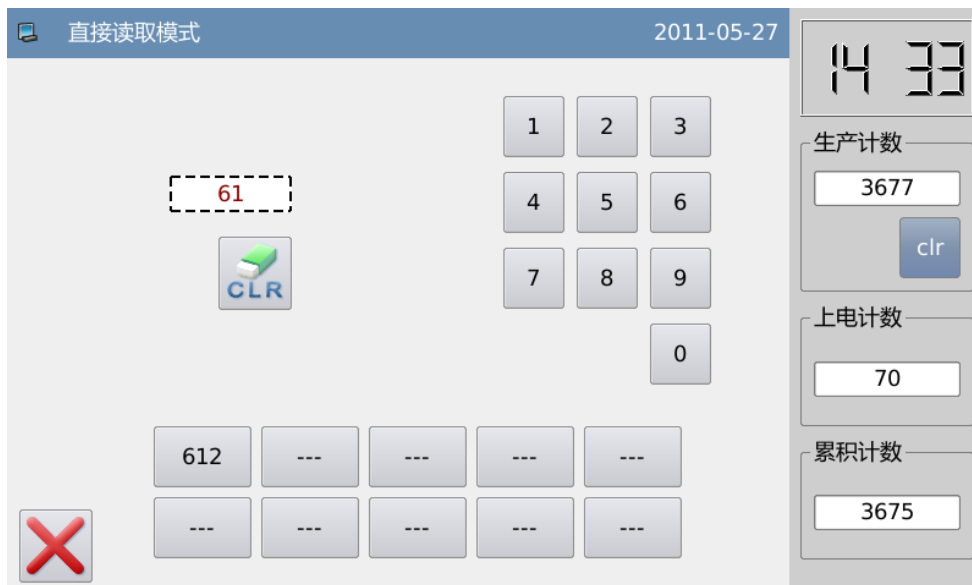

2.5.2 Free Memory

In the interface for loading pattern, user can press  to check the usage condition of the memory.

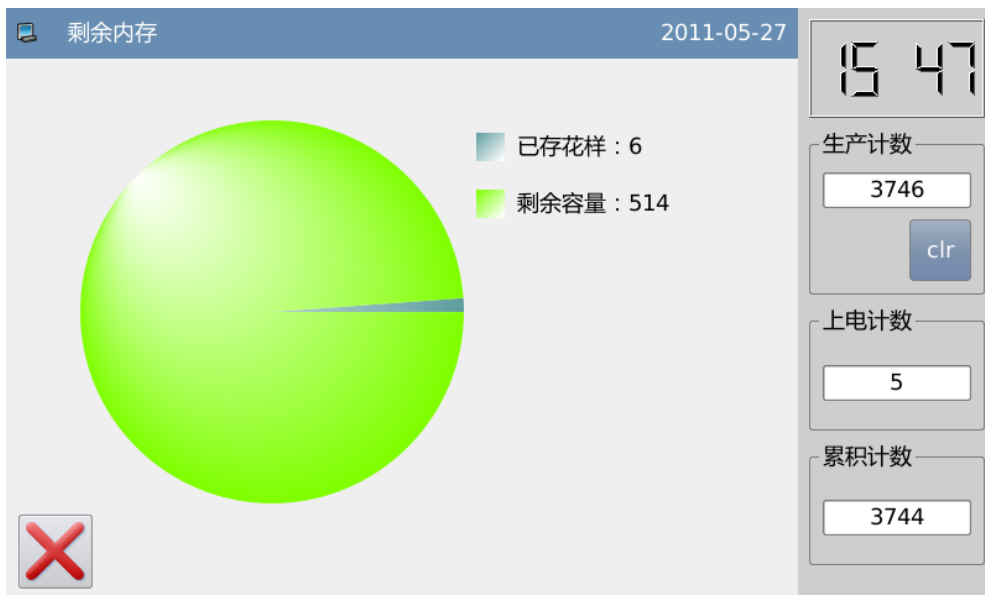

2.5.3 Delete Pattern

User can press  to delete a pattern. At this moment, the system will display “Delete Pattern from Memory” (If the system is at U Disk Load Mode, the system will display “Delete the Selected File”). User needs follow the point information, but he cannot delete the pattern being sewn.



2.5.4 Supported Data Format

At present, the supported format by the system are: B format, BA format, VDT format, EMB format, DST format, DSB format and DSZ format.

2.5.5 Display Style of Pattern List

Press “LCD” -> “Display Style of Pattern Selection” to shift the display style of the pattern loading interface.



Set that parameter at “Display Pattern Shape” and return to the pattern load interface to view the patterns used.



[Note]: Only can the used patterns be displayed in the pattern shape list.

[Note]: User can set it at “Function Setting” -> “Display Setting Mode”.

2.6 Save Pattern





Function:

No.	Functions	Content
A	Input Pattern Name	Display the pattern name
B	Input Pattern Number	Display the pattern number
C, D, F, J & K	Same as Pattern Load Interface	Refer to the descriptions in Pattern Load Interface
E	Keyboard	Input name or number
G	Caps Lock	Shift between capital letters and lowercase letters (When the button is in shadow, the inputted letter will be the capital letters.).
H	Clear All Letters	Press it to clear all the inputted figures
I	Clear Single Letter	Press it to clear the first figure at the left of the icon.

Operation:



1. Have Access to Pattern Load Interface

In main interface P1 (or P2), press  to activate the catalogue mode, and then press  .

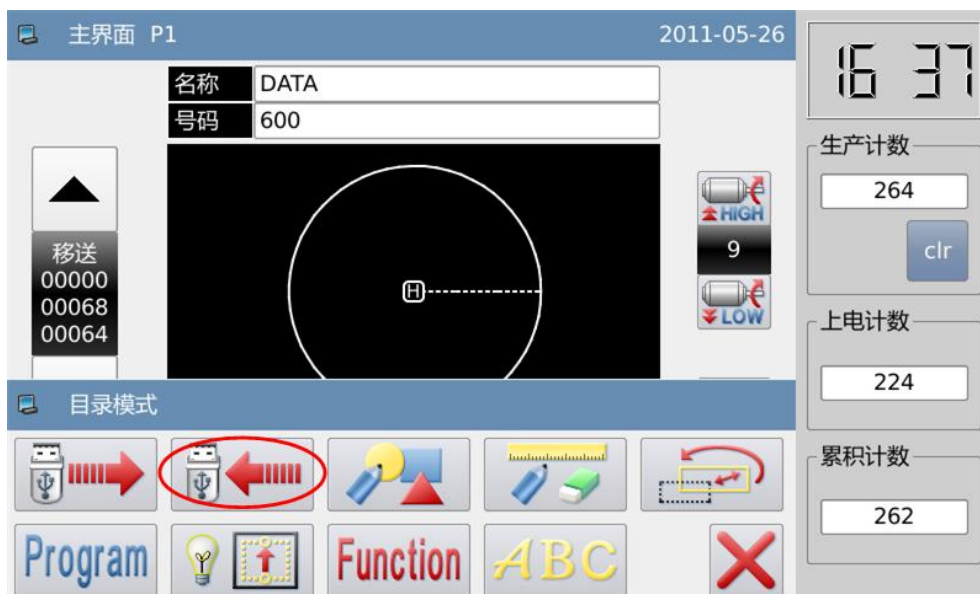

[Note]: If the icon is not at the origin, the system will be unable to save pattern. Therefore, please perform the operation for returning to origin firstly.



2、Set Name and Number

The default setting in this interface is the Memory Save Mode (you can see  at the upper left of the screen). You can press  to shift to U Disk Save Mode, which is shown at below:

Press or to input the name or number

Pressing  is to delete the first figure at the left of the icon, while pressing  is to clear all the figures.

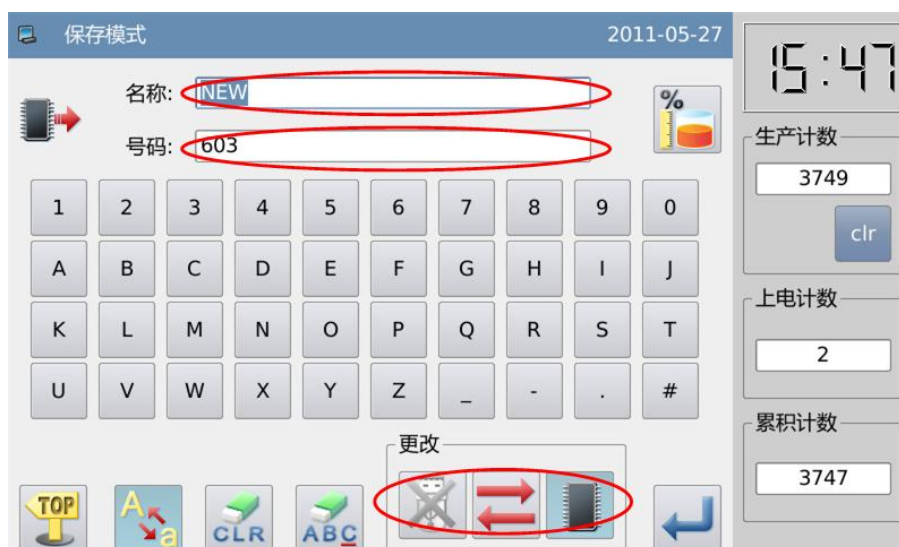

If user needs capital letters, please press .

[Note]: User can input at most 8 figures for a name of pattern; the range for number input is “400”~ “599” and “600” ~ “799”.



3、 Save Pattern

After the input, press  to return to the main interface directly



[Note]: If the memory contains the pattern with the number same to that of the inputted one, the system will display “Replace Pattern in Memory”. Press  to cancel the replacement; press  to perform the replacement.

2.7 Operation Setting

It is to set each parameter. For the description of parameter, please refer to [2.7.6 Parameter List].

2.7.1 Setting Method

1、 Have Access to Operation Setting:

In main interface P1 (or P2), press  to activate the catalogue mode, and then press .

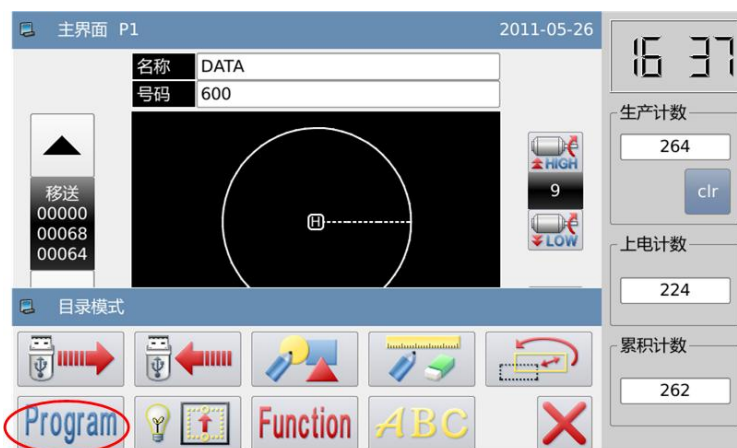

2、 Interfaces at Setting Mode

After having access to the operation setting interface, user can use  to turn the pages for selecting parameters.





3、Example :

① Mode Selection

Select the parameter for setting to activate the “Internal Parameter Setting Interface”. At here, we press “Pressing Board”



② Internal Parameter Setting Interface

Select the parameter to activate the “interface for changing the set value”. (We press “POP” here.)



③ Change Set Value of Parameter

Press parameter to change the set value

(here, we press “ILR”). Then, press  to confirm it.

[Note]: Pressing  is to display the descriptions of that parameter and its value.



④ Check the Changed Parameter Value

Return to the interface for setting internal parameter, where user can check the value after change. Press  to quit.



⑤ Return to Mode Selection Interface

Return to “Mode Selection” interface. Because the value is changed, the button “The Changed Settings” is displayed.

For returning to main interface P1 (or P2), please press .

For checking the content of the changed settings, please press “The Changed Settings”



⑥ Check the Content of the Changed Parameter

a) Have access to password input mode

Pressing “The Changed Settings” in the “Mode Selection” interface, will activate the Password Input Mode, where user can enter the Changed Parameter Setting Mode after he gives the correct password. (For setting the password, please refer to [2.7.3 Parameter Encryption])



b) Have Access to Changed Parameter Setting Mode

In this interface, the changed content of the parameter will be displayed. If user wants to change it again, he can change it in this interface (Here, he needs press “POP”)

If user wants to restore the changed parameters, he should press the button with the name of that parameter (At here, he can press “Pedal Operation Method”, “Intermediate Presser Down Synchronization”) and click “Restore”. After that user only needs to follow the instruction of the system.

If user wants to restore the entire setting to their default values, he can press “Restore All”. After that user only needs to follow the instruction of the system.



2.7.2 Types of Parameter Setting

There are two ways for setting parameter: the one is selection; the other is input, as shown in below:



Selection





Input

2.7.3 Parameter Encryption

In the parameter mode, each entrance can be attached a password, so as to avoid the manual mis-operation.

1、Have Access to Parameter Encryption Interface:



In main interface P1 (or P2), press  to activate the catalogue mode, and then press **Function** to have access to the interface for setting functions.

In the function setting interface, press  .









2、Input Password:

Before having access to the Parameter Encryption Mode, user needs input password. (The original password is the manufacturer ID).

If user inputs the wrong figure, pressing  will delete the first figure at left of the icon, while pressing  will delete the entire figures inputted.

Input the password and press  .





<p>2、 Select Parameter for Encryption:</p> <p>As shown in picture, user can select one or many parameters for encryption. (Here, we select “Pause”.)</p> <p><input checked="" type="checkbox"/> 暂停 : Selected <input type="checkbox"/> 暂停 : Unselected</p> <p>After selecting the parameter for encryption, user can press  .</p> <p>From then on, user has to input password when setting the parameter that was encrypted.</p> <p>For changing password, please press  .</p>	
<p>3、 Change Password</p> <p>In the interface of setting new password, press  .</p> <p>当前密码: <input type="text"/></p> <p>, 新密码: <input type="text"/> & 确认密码: <input type="text"/> in order and input the current password, new password, confirmation respectively. At last press  .</p> <p>[Note]: The original password is the manufacturer ID. After setting the password, the “Current Password” is the password set at last time</p>	

2.7.4 Recovery and Back-up of Parameter

User can save the changed parameter into U disk for the recovery operation in future.

1、 Have Access to Interface of Parameter Recovery and Back-up:

In main interface P1 (or P2), press  to activate the catalogue mode, and then press **Function** to have access to the interface for setting functions.

In the function setting interface, press .

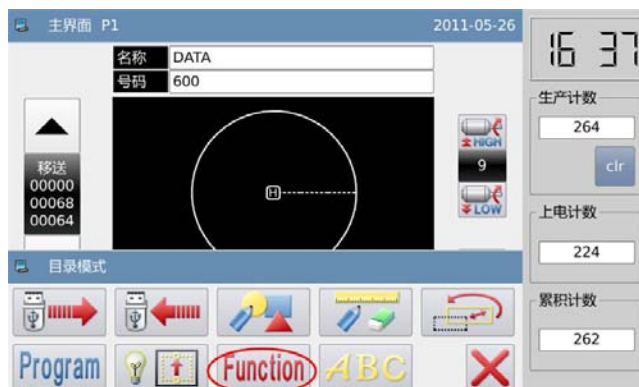

2、 Back up Parameters

In the interface of parameter recovery and back-up, the default setting is to back-up the parameters.

After inserting the U disk, user needs press . After the operation, the system will create catalogue called as “bakParam” in U disk automatically. The file “backup.param” within that catalogue is the parameter back-up file

[Note]: the file with the same name will be replaced with new data. The original data will be lost.

In parameter recovery operation, user can press  to shift to recovery mode.



3、Parameter Recovery



At recovery mode, press  to recover the parameters. After the operation, the system will return to the previous level.





2.7.5 Default Parameter Recovery

User can restore the parameters to their default values. Additionally, user can also save the set parameters for the usage in future.

1、Have Access to Default Parameter Recovery:

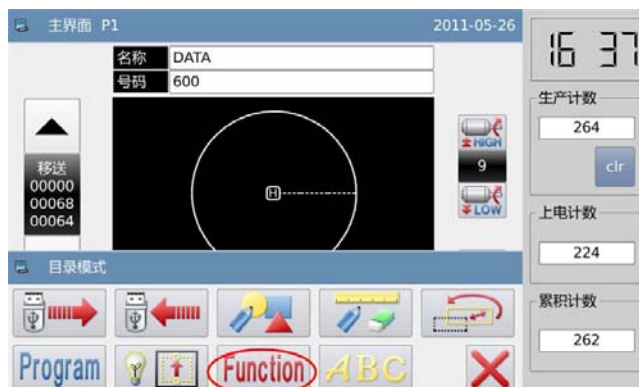
In main interface P1 (or P2), press  to activate the catalogue mode, and then press  to have access to the interface for setting functions.



In Function Setting Interface, press  and then input the password (the original password is the manufacturer ID). After user inputs the correct password, user can have access to Default Parameter Mode





2、 Use the Default Parameter

Click the corresponding default parameter and then

press  to reload that value



After the reloading, the system will return to the upper interface automatically

[Note] Some important parameter, like “Main Stop Angle” can not be restored in this operation.



3、 Save Customized Parameter

Press  to have access to the interface for saving parameters, where user can save the parameter value after the setting.

Click  or  to confirm the position for saving that parameter. Then

click  to save it.

After the saving, the system will return to the upper interface automatically

[Note] The parameter for repair and maintenance can not be saved

[Note] The motor installation angle and motor parameters can be saved.



4、Load Parameter Saved by User

Have access to that interface. Check the content on button “Customized Parameter (Y/N)”. If it is Y in the bracket, it means that position has customized parameter.

Click that key and press  to reload the corresponding parameter. After the operation, the system will return to the upper interface.



2.7.6 Parameter List

1、Thread Adjuster:

Code	Brief	Details	Unit	Step Length	Range	Default Value	Type
WIP	Thread Adjuster Switch	Thread adjuster (W) switch			0:OF:Thread Adjuster off 1:ON:Thread Adjuster on	1	Selection
W1	Thread Adjuster Start Time	Set the start time of thread adjuster (W) according to the thread-trimming order. Usually, it has no need to change.	ms	2	0~998	30	Input
W2	Thread Adjuster Work Time	Set the working time of thread adjuster (W) according to the thread-trimming order. User can prolong the time if necessary.	ms	2	0~998	30	Input
W3	Thread Adjuster Stop Delay	The delay time for the device return after the action of thread adjuster (W)	ms	1	0~255	0	Input

2、Slow Start Stitch:

Code	Brief	Details	Unit	Step Length	Range	Default Value	Type
ST1	Start Speed of 1 st Stitch	Start Speed of 1 st Stitch	100RPM	1	2~27	3	Input
ST2	Start Speed of 2 nd Stitch	Start Speed of 2 nd Stitch	100RPM	1	2~27	5	Input
ST3	Start Speed of 3 rd Stitch	Start Speed of 3 rd Stitch	100RPM	1	2~27	10	Input
ST4	Start Speed of 4 th Stitch	Start Speed of 4 th Stitch	100RPM	1	2~27	15	Input
ST5	Start Speed of 5 th Stitch	Start Speed of 5 th Stitch	100RPM	1	2~27	20	Input

3、Pressing Board:

Code	Brief	Details	Unit	Step Length	Range	Default Value	Type
SYN	Sewing When Board Is Up	Can the machine perform sewing when the board is up			0:OF: No 1:ON:Yes	0	Selection
TFS	Presser Status at Sewing End	Frame Status at Sewing End			0:SUP: Back to start point and go up 1:SLU: Go up at sewing end. 2:SBU: Back to start point. It goes up when user steps pedal.	0	Selection
ATU	Pressing Board Auto Up after Work	After working, the pressing board goes up automatically.			0:PUP:Auto UP 1:NUP:Not Auto Up	0	Selection
POP	Pedal Operation Method	Pedal Operation Method			0:BUD:Frame Up/Down 1:IUD: Indirect Control Frame & Help Frame Up/Down 2:ILR: Indirect Control L/R Frame	0	Selection
LRD	Lower Action of L/R Presser	Lowering action of left presser and right presser			0:LRU:Down at Same Time 1:LRN:Left Then Right 2:RLD:Right Then Left	0	Selection
LRU	Lift Action of L/R Presser	Lifting action of left presser and right presser			0:LRT:Presser Up after work 1:LTD:Left Presser Down After Work 2:RTD: Right Presser Down After Work	0	Selection
DYN	Special Presser	Support Reverse & Stretch 0- No 1- Reverse Presser 2- Stretch Presser		1	0-255	0	Input
YOR	Reverse Device	Reverse Device Auto-reverse	0.1m	1	0~1000	170	Input

	Auto-reverse Y Coordinate	Y Coordinate	m				
PSS	Presser Status at Stop	Presser Status at Stop			0:UP:Presser Down 1:DN:Presser Up	0	Selection

4、 Range Limitation:

Code	Brief	Details	Unit	Step Length	Range	Default Value	Type
ALC	Cancel Range Protection	Cancel Range Protection			0:OF:Protection Off 1:ON:Protection On	1	Selection
XL	Set Effective Range in Left X Direction	Set effective range in left X direction	mm	1	2~255	101	Input
XR	Set Effective Range in Right X Direction	Set effective range in right X direction	mm	1	2~255	101	Input
YU	Set Effective Range in Up Y Direction	Set effective range in up Y direction	mm	1	2~255	51	Input
YD	Set Effective Range in Down Y Direction	Set effective range in down Y direction	mm	1	2~255	51	Input

5、 Thread-breakage Detector:

Code	Brief	Details	Unit	Step Length	Range	Default Value	Type
PRT	Thread-breakage Detection	Thread-breakage Detection			0:OF: OFF 1:ON:ON	0	Selection
ISD	Invalid Stitch at Sewing Start for Thread-breakage Detection	Invalid Stitch at Sewing Start for Thread-breakage Detection		1	0~15	8	Input
IND	Invalid Stitch during Sewing for Thread-breakage Detection	Invalid Stitch during Sewing for Thread-breakage Detection		1	0~15	3	Input
TRM	Trim at Thread-breakage Detection	Trim at Thread-breakage Detection			0:ON: Trim at Thread-breakage 1:OF: Not Trim at Thread-breakage	0	Selection
PRT	Thread-breakage Detection	Thread-breakage Detection			0:OF: OFF 1:ON:ON	0	Selection

6、 Origin Position:

Code	Brief	Details	Unit	Step Length	Range	Default Value	Type
PTR	Return to Origin at Power-on	Return to origin at power-on			0:OF:Not Return 1:ON:Return	0	Selection
PRF	Forbid Returning to Origin at Presser Up	Forbid returning to origin at presser up			0:OF:Permitted 1:ON:Forbidden	0	Selection
DOG	Search Origin at Sewing End	Search origin at sewing end			0:OFF:Not Search Origin, Stop at End Point 1:ON:Search Origin (Sub-origin) 2:RET:Return to Start Point	1	Selection
RST	Set Start Point Resetting Path	Set start point resetting path			0:LIN:Linear Return Start Point 1:PAT:Return Origin in Pattern 2:ORG:Search Origin Then Return to Start Point	0	Selection
DED	Select Upper Dead Point at Searching Origin	Whether select upper dead point at searching origin			0:OF:Not Select 1:ON:Select	0	Selection
OPR	Origin Presser Action	Origin presser action			0:DNW:Presser Down 1:UP:Presser UP	1	Selection
NRM	Search/Return to Origin Path	Patch selection of searching/returning to origin			0:NRM: Standard 1:REV: Reverse 2:YTX:Y to X 3:XTY:X to Y	0	Selection
REV	Select Search/Return to Origin Path at Reverses	Patch selection of searching/returning to origin at reverse			0:NRM: Standard 1:REV: Reverse 2:YTX:Y to X 3:XTY:X to Y	0	Selection
MDO	Enable Origin Correction	Enable the function of origin correction			0:OF: Unable 1:ON: Enable	0	Selection
XSP	X Sensor Position	X sensor is at the left or right side of the head			0:L:Left 1:R:Right	0	Selection

7、Pause :

Code	Brief	Details	Unit	Step Length	Range	Default Value	Type
POS	Needle Position at Pause	Needle position at pause			0:DWN:Needle Down Position	1	Selection

					1:UP:Needle Up Position		
ACT	Presser Action at Pause	Presser action at pause			0:DWN:Presser Down 1:UP: Presser Up	0	Selection
TYP	Pause Switch Type	Pause switch type			0:AUT:Auto Lock 1:NRM:Normal	0	Selection
TRM	Auto Trimming at Pause	Auto trim at pause			0:AUT:Auto trim 1:OFF:No trim	0	Selection

8、Counter:

Code	Brief	Details	Unit	Step Length	Range	Default Value	Type
UCM	Up Counter Mode	Up counter mode			0:OFF:Up Counter Off 1:PAT:Count by Pattern 2:CYC:Count by Cycle	1	Selection
DCM	Down Counter Mode	Down counter mode			0:OFF:Down Counter Off 1:PAT:Count by Pattern 2:CYC:Count by Cycle	1	Selection
URV	Reserve Up Counter Value at Inputting Pattern	Reserve up counter value at inputting pattern			0:CLR:Clear 1:RSV:Reserve	1	Selection
DRV	Reserve Down Counter Value at Inputting Pattern	Reserve down counter value at inputting pattern			0:CLR:Clear 1:RSV:Reserve	1	Selection
POC	Clear Counter at Repowering	Clear counter value at repowering			0:CLR:Clear 1:RSV:Reserve	1	Selection
NUP	Cannot Change Up Counter (UP)	Cannot change up counter (UP)			0:OF: Permitted 1:ON:Forbidden	0	Selection
NDP	Cannot Change Down Counter (DN)	Cannot change down counter (DN)			0:OF: Permitted 1:ON: Forbidden	0	Selection
UTO	Sewing Machine Action at Reaching Up Counter (UP) Set Value	Sewing machine action at reaching up counter (up) set value			0:OF:Stop Sewing 1:ON:Continue Sewing	0	Selection
DTO	Sewing Machine Action at Reaching Down Counter (DN) Set Value	Sewing machine action at reaching down counter (DN) set value			0:OF:Stop Sewing 1:ON:Continue Sewing	0	Selection

9、Intermediate Presser:

Code	Brief	Details	Unit	Step Length	Range	Default Value	Type
SYN	Down Synchronization	Synchronization of lowering intermediate			0:BEF: Before Head Start	0	Selection

		presser			1:OUT:Same with Last Out Presser		
CUR	Intermediate Presser Current	Intermediate presser current		1	2~8	4	Input
DLY	Intermediate Presser Up Delay	Delay the action to prevent running into mould	ms	1	0~255	0	Input
TYE	Intermediate Presser Type	Select type of intermediate presser			0:AIR:Air Valve 1:STP: Stepping 2:MAG:Magnet	0	Selection
PLP	Intermediate Presser Stroke Setting	Set intermediate presser vertical stroke.	0.1mm	2	0~180	150	Input
ZU8	Intermediate Presser Up Angle	Set up position for moving intermediate presser	Degree	1	0~360	100	Input
ZD8	Intermediate Presser Down Angle	Set down position for moving intermediate presser	Degree	1	0~360	0	Input
ZTM	Synchronization of Intermediate Presser at Inputting	Input pattern at setting intermediate presser			0:OFF: Not Relating to Pattern Input 1:ON: Relating to Pattern Input	1	Selection
PDD	Intermediate Presser Down Delay	Delay at lowering the intermediate presser		1	0~255	0	Input

10、Winding:

Code	Brief	Details	Unit	Step Length	Range	Default Value	Type
SPD	Winding Speed	Set wind speed	100RPM	1	2~27	13	Input
STP	Winding Device Stop Method	Set method to stop winding			0:UTS: Release Pedal to Stop winding 1:RTS:Step Pedal again to stop winding 2:TTS: Set Time to Stop Winding	1	Selection
TPD	Set Stop winding time (Unit Second)	Set the time to stop winding (Unit Second)	s	2	2~498	30	Input

11、Feed Method:

Code	Brief	Details	Unit	Step Length	Range	Default Value	Type
TYP	Pressing Board Type	Select Pressing Board			0:AIR:Air-driven	0	Selection

						1:MAG: Magnet 2:ADP: Self-adopt		
WEI	Weight of Pressing Board	Select the weight of pressing board				0:HIG: Light 1:MID:Middle 2:WEG:Heavy	1	Selection
HIG	Light Board (Air Amount L)	Light board (Air Amount L)		1		0~255	145	Input
MID	Middle Board (Air Amount M)	Middle board (Air Amount M)		1		0~255	0	Input
WEG	Heavy Board (Air Amount H)	Heavy board (Air Amount H)		1		0~255	0	Input
STP	Sewing Type Selection	Select sewing type				0:TIN:Thin 1:MID:Middle 2:TIC:Thick	0	Selection
THIN	Thin Fabric	Thin fabric thickness		1		0~255	0	Input
MID	Middle Fabric	Middle fabric thickness		1		0~255	0	Input
THCK	Thick Fabric	Thick fabric thickness		1		0~255	0	Input
SUI	Pattern-making Follows Action Setting	Pattern-making follows the action setting				0:OF: Forbid 1:ON: Permit	1	Selection
SMD	Start Frame-moving Angle Adjustment	Adjust the start frame-moving angle	Degree	1		-50~+50	0	Input
STD	End Frame-moving Angle Adjustment	Adjust the end frame-moving angle	Degree	1		-50~+50	0	Input
SAE	Frame-moving Initial Angle Setting	Set the initial frame-moving angle with speed over 1800rpm	Degree	1		135-280	135	Input
MMD	Move Mode	XY axis action mode				0:ETM: Equal Time 1:NTM: Unequal Time	0	Selection

12、Speed:

Code	Brief	Details	Unit	Step Length	Range	Default Value	Type
HSP	High Speed	Set high speed	100RPM	1	2~27	23	Input
LSP	Low Speed	Set low speed	100RPM	1	2~27	2	Input
MHS	Middle High Speed	Set middle high speed	100RPM	1	2~27	15	Input
MLS	Middle Low Speed	Set middle low speed	100RPM	1	2~27	10	Input
EDL	Feed Delay	Delay after feeding action		1	0~9999	0	Input
JDL	Step Moving Delay	Delay after step moving action		1	0~9999	0	Input
IDL	Pattern-making Delay	Delay after pattern-making action		1	0~2700	0	Input
SEW	Sewing Speed	Set sewing speed		1	0~9	4	Input

FED	Feed Speed	Set speed at empty feed section		1	0~9	4	Input
FRM	Frame-moving Speed	Set frame-moving speed		1	1~3	3	Input
SPS	Returning to Start Point Speed	Set speed for returning to the start point		1	0-9	4	Input
HPS	Search Origin Speed	Set speed for searching origin		1	5~10	5	Input
SMS	Single Step Move Speed	Set speed of moving of single step		1	0~40	30	Input

13、 Thread-trimming Order:

Code	Brief	Details	Unit	Step Length	Range	Default Value	Type
TRM	Trimming Switch	Trimming Switch			0:OFF:Off 1:ON:On	1	Selection
SPD	Trimming Speed	Trimming Speed	10RPM	1	20~40	40	Input
ANG	Needle Position Angle After Trimming	Needle position angle after trimming			0:UP: Upper Needle Position 1:DED: Upper Dead Point	0	Selection
DLY	Thread-trimming delay	Thread-trimming delay	0.01s	1	0~255	12	Input
TST	Trimming Output Start Time/ Angle	Trimming output start time/ angle	mm/ Degree	2	0~998	210	Input
TET	Trimming Output End Time/ Angle	Trimming output end time/ angle	mm/ Degree	2	0~998	0	Input
TMD	Trimming Mode	Select thread-trimming order			0:FST:fast 1:GEN:Gentle	1	Selection
OPT	Thread-loosing Delay	Thread-loosing delay		1	0~255	0	Input
OSA	Thread-loosing Start Time/Angle	Thread-loosing start time/angle	mm/ Degree	2	0~998	300	Input
OEA	Thread-loosing End Time/Angle	Thread-loosing end time/angle	mm/ Degree	2	0~998	0	Input

14、 LCD Screen:

Code	Brief	Details	Unit	Step Length	Range	Default Value	Type
WRN	Warning of Buzzer	Set the warning voice of buzzer			0:OFF: No Voice 1:PAR:Panel Voice 2:ALL:Panel + Warning Voice	2	Selection
DEL	Touching Panel Sensitivity Adjustment	Adjust sensitivity of touching panel		1	1~5	3	Input
LIG	Back Light Adjustment	Adjust the back light		1	20~100	100	Input
ATO	Back Light Auto	Auto turn-off of back			0:OF:Not Auto	0	Selection

	Turn-off	light			Turn-off 1:ON:Auto Turn-off		
TIM	Back Light Auto Turn-Off Waiting Time	Time for waiting auto turn-off of back light	Minute	1	1~9	3	Input
BTN	Button Display Style	Set the display style of the button in Test Mode and Function Mode			0:ICN: Icon 1:TXT: Text	0	Selection
BKC	Background Color Setting	Set the background color of the pattern display area in main interface 0: Block 1: Dark Blue 2: Red 3: Green 4: Blue 5: Purple 6: Yellow		1	0~6	0	Input
SES	Display Style of Pattern Selection	Set the display style of pattern-selection interface Note: only the used patterns can be displayed.			0:CLS:Classic (Display Number List) 1:SHP: Display Pattern Shape	0	Selection
EPS	Pattern-making Style	Display style of pattern-making			0: Style 1 1: Style 2	0	Selection

15、Others:

Code	Brief	Details	Unit	Step Length	Range	Default Value	Type
NLD	Needle-cooling	Needle cooling device			0:OFF:No 1:ON:Yes	0	Selection
PEM	Permission of Single Pedal Operation	Permission of single pedal operation			0:OFF: Forbidden 1:ON: Permitted	0	Selection
LAG	Language Selection	Language selection			0:CH:中文 1:EN:English	0	Selection
SSW	Sound Setting	Set sound function			0:OFF:Off 1:ON:On	1	Selection
VOL	Volume of Operation Voice	Volume at pressing button			30~63	50	Input
NSW	Network Connection	Activate the network connection			0:OFF:Off 1:ON:On	0	Selection

16、Repair & Maintenance:

Code	Brief	Details	Unit	Step Length	Range	Default Value	Type
------	-------	---------	------	-------------	-------	---------------	------

NRT	Needle Replacement Left Value	Left stitches for needle replacement	1000 Stitch	1	0~9999	0	Input
NST	Needle Replacement Set Value	Set stitches for needle replacement	1000 Stitch	1	0~9999	0	Input
HRT	Clearing Time Left Value	Left hours for clearing	Hour	1	0~9999	0	Input
HST	Clearing Time Set Value	Set hours for clearing	Hour	1	0~9999	0	Input
ORT	Oil Replacement Left Value	Left hours for oil replacement	Hour	1	0~9999	0	Input
OST	Oil Replacement Set Value	Set hours for oil replacement	Hour	1	0~9999	0	Input

[Note]: Parameters, like NRT, HRT and ORT can not be set. User can only check them in the Internal Parameter Setting Interface

[Note]: After the modification of parameters for repair and maintenance, the corresponding parameters of “Left Value” will be changed to the set value

[Note]: After the parameter value of repair and maintenance are set (value over 0), the corresponding counting function for repair and maintenance will be activated as well.

17、Special:

Code	Brief	Details	Unit	Step Length	Range	Default Value	Type
HSP	Max Speed	Max Speed	100RPM	1	2~27	23	Input
MAE	Main Stop Angle	Stop angle of main shaft motor	Degree	1	30~80	53	Input
DEB	Letter Embroidery	Activate letter embroidery			0:OF:Turn off Letter Embroidery Function 1:ON: Turn on Letter Embroidery Function	1	Input
DAE	Upper Dead Point Angle	Set angle from stop point to upper dead point	Degree	1	0~50	3	Input
RSC	Stitch Length Deceleration Curve	Select built-in stitch length deceleration curve		1	0-6	5	Input
HSL	Max Stitch Length at Keeping Speed	Max stitch length at keeping highest speed	0.1mm	1	1-127	0	Input
MTS	Main Shaft Motor Type Selection	Support 550W & 750W			0-550W 1-750W	1	Selection

2.8 Test Mode

In main interface P1 (or P2), press



to activate the catalogue mode,

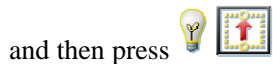

and then press to have access to the test mode.

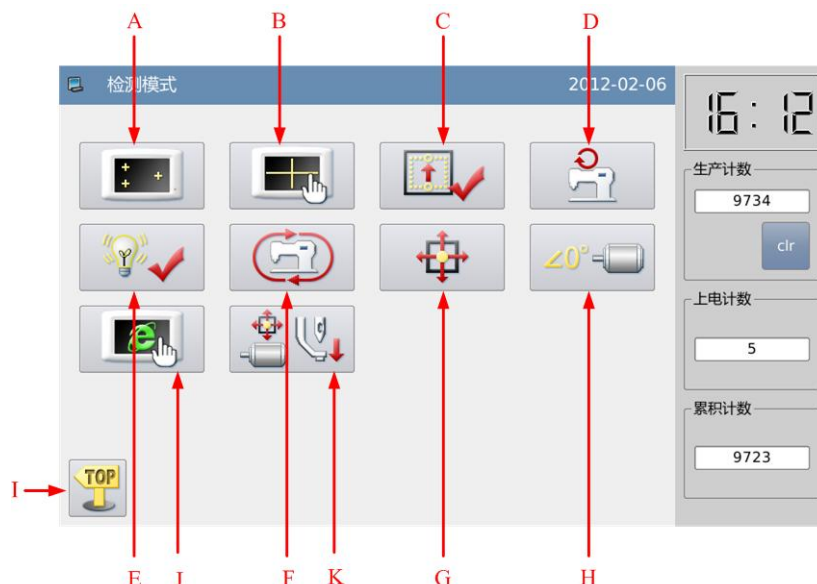
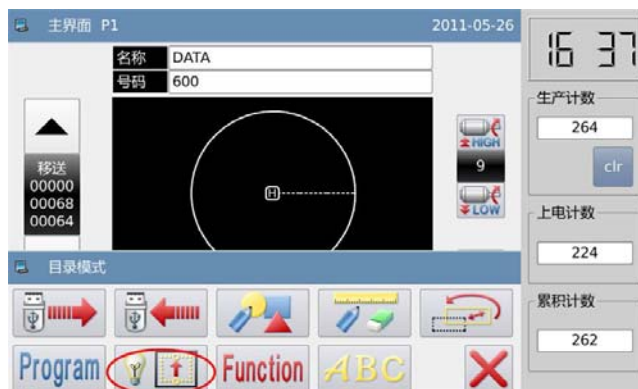



Functions:

No.	Functions	Content
A	LCD Test	Test LCD displayer
B	Touching Panel Correction	Correct the touching panel
C	Input Signal Test	Test the input signal of switches and sensors
D	Speed Test	Test the speed of main shaft motor
E	Output Signal Test	Test the output signal of pressers and thread-trimming devices
F	Continuous Running	Set continuous running parameter and enter aging status
G	XY Motor Origin Test	Test the motor origins of X /Y motor
H	Main Motor Installation Angle Adjustment	Display and set the installation angle of main shaft motor
I	Quit	Quit test mode and return to main interface
J	Network Setting	Set the relating parameters of network
K	Intermediate Presser Test	Test the statuses of intermediate presser motor and sensor

2.8.1 LCD Test

Function:

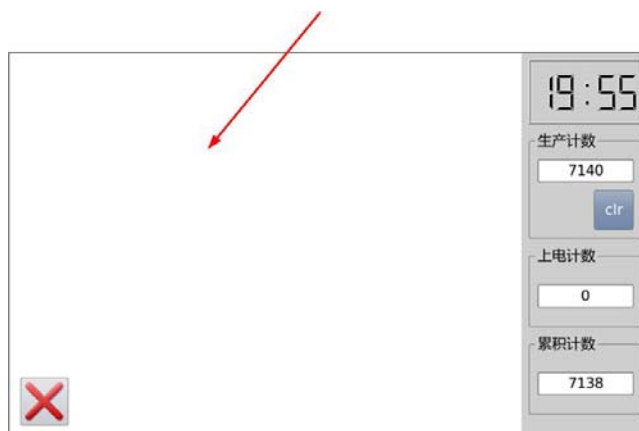

In the test mode, press  to activate LCD test function. Click the area other than the  to have LCD screen display white, black, red green and blue so that user can judge whether the LCD screen has problem.

Press  to return to the upper level interface.



2.8.2 Touching Panel Correction

Functions:

In the test mode, press . At this moment, the system will display "Confirm to enter touching panel correction mode?" Press  to have access to the touching panel correction function.



User has to correct 5 spots. The touching pen is recommended to be used at touching the cross icon on the interface. After the correction, the system will display the result of this operation

[Note]: During the correction, please perform the operation strictly according to the position of the cross icon, or the touching panel may be unable to be used normally after the correction.

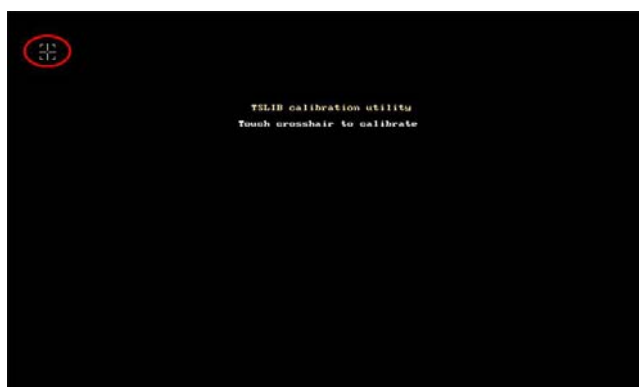

2.8.3 Input Signal Test

Function:

In the test mode, press  to set the Input Signal Test Function.

ON: Activation

OFF: Deactivation

Types of Input Signal:

- ① Start switch (Pedal)
- ② Pressing board (Pedal)
- ③ Pause Switch
- ④ Thread-breakage Detection
- ⑤ X Motor Sensor
- ⑥ Y Motor Sensor



Press  to return to the upper level interface.



2.8.4 Main Shaft Speed Test

Functions:

In the test mode, press  to set the main shaft speed test function.

Use  and  to set the aim speed of main shaft motor. After user

presses , the main shaft motor will rotate in the set speed. At this moment, the actually measured speed will be displayed in the input column of actual speed.

Press  to stop running

Press  to return to the upper level interface.



2.8.5 Output Signal Test

Functions:

In the test mode, press  to activate the output signal test function.

In this interface, user can press output signal button to test the status of output signals of solenoids

Output signals:

- ① Thread-stirring
- ② Thread-trimming
- ③ Presser
- ④ Intermediate presser
- ⑤ Thread-loosing
- ⑥ Reverse Presser

Press  to return to the upper level interface.

[Note]: The sewing machine will have the actual movement.



2.8.6 Continuous Running

Function:

In the test mode, press  to set the continuous running function

Click Action Interval bar or Origin Detection of Needle-withdrawing bar and use number keys to input the figures.

Press  to return to the upper level interface.

Return to main interface P1 (or P2). Step pedal to run the machine, and have access to continuous running mode.

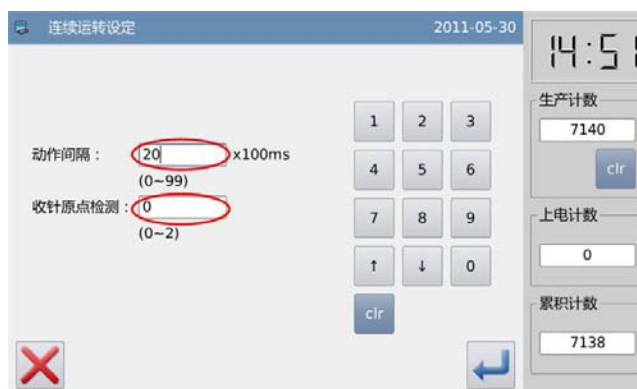

2.8.7 XY Motor Origin Test

Functions:

In the test mode, press  to activate the XY Motor Origin Detection Function.

In this interface, use direction keys to move XY motor. During this process, the system will display the ON/OFF status of the sensors.

ON: Sensor Detected

OFF: Sensor Undetected

Press  to return to the upper level interface.

[Note]: The sewing machine will have the actual movement.

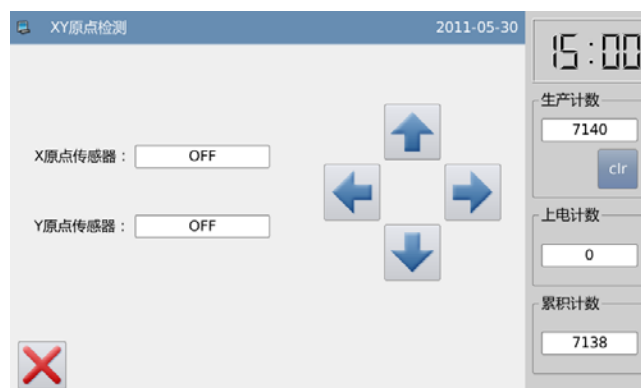

2.8.8 Main Motor Installation Angle Adjustment

Functions:

In the test mode, press  to set the main motor installation angle adjustment.

In the current interface, remove the main motor, turn the hand wheel to lift the needle to the highest point and turn the main shaft joint to adjust the electrical angle to less than 30 degree. After that, reinstall the

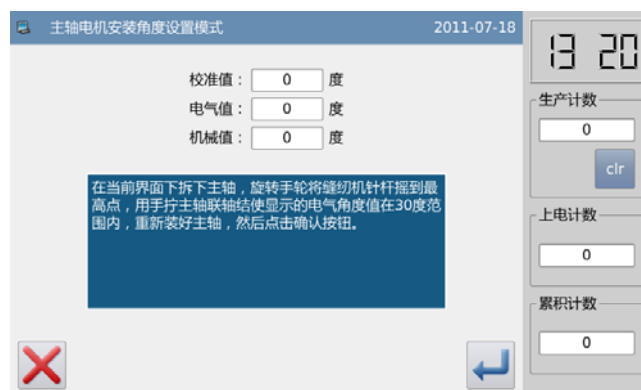

main motor and press .



2.8.9 Network Setting

Functions:

In the test mode, press  to set the network functions. If user needs the network function of operation head, he should set the relating parameters of network

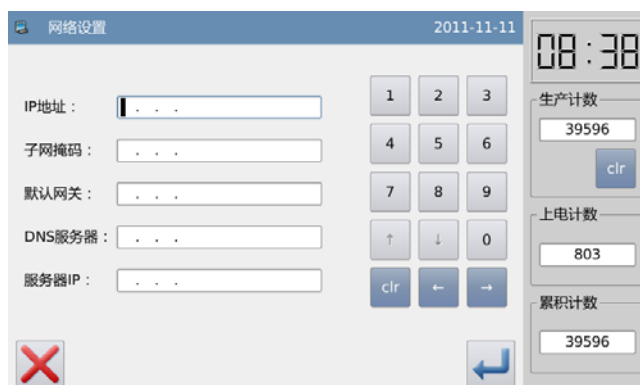

Use number keys to input parameters, make sure the “IP Address” and “Server IP” are in the same section. Use  and  to move icon.



2.8.10 Intermediate Presser Test

Functions:

In the test mode, press  to set intermediate presser test.

- :Intermediate Presser Down
- :Intermediate Presser Up
- :Shift Intermediate Presser

Position

[Note]: In this interface, step pedal to return the intermediate presser to origin (the highest position of intermediate presser); the highest point is 71mm, middle point is 35mm, the lowest point is 0mm. The adjusted position is the fabric thickness.

This function is only available for G Type.



2.9 Function Setting

In main interface P1 (or P2), press



to activate the catalogue mode,

and then press **Function** to have access to the Function Setting Mode.

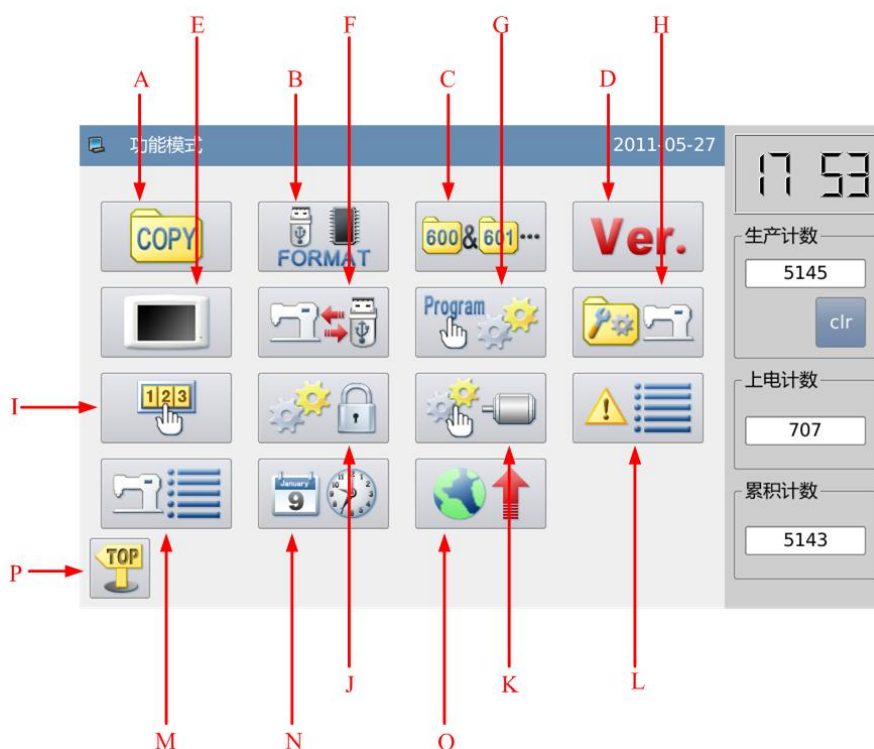
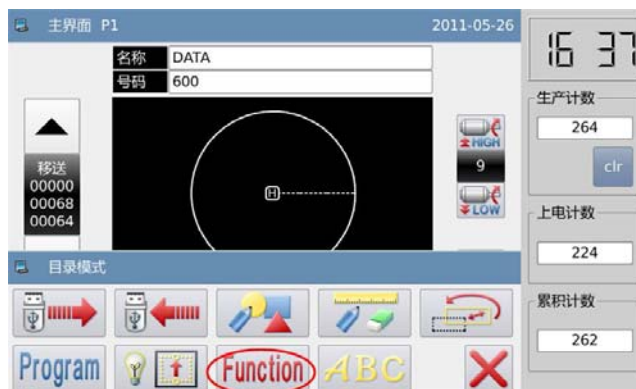

Functions:

No.	Functions	Content
A	Data Transfer	Transfer pattern file between memory and U disk
B	Formatting	Initialize the U disk, memory and pattern number hotkeys.
C	Pattern Connection	Edit Combination Pattern
D	Version Inquiry	Inquire the version of system software
E	Display Setting	Set background light, keyboard lock, lightness and so on
F	Back-up Parameter Recovery	Save parameter values into U disk for the parameter recovery in future
G	Default Parameters	Recovery the default parameter value and self-defined the input/output function.



H	Pattern Number Hotkey Edition	Edit the content of pattern number hotkey
I	Password Mode	Provide periodical password function
J	Parameter Encryption	Set passwords for each operation entrance in parameter mode.
K	Motor Configuration	Enter main motor, stepping current configuration mode
L	Alarm Record	Check the alarm statistic information
M	Running Record	Check running information of machine
N	Date & Time Setting	Set data and time
O	Software Update	Have access to software update mode
P	Quit	Return to main interface



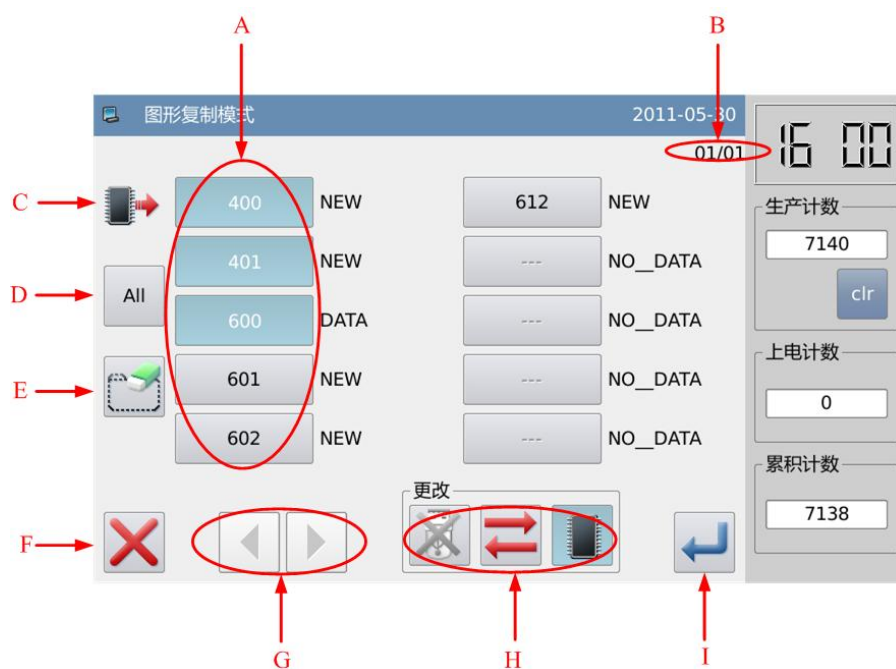

2.9.1 Data Transfer Mode

In function setting interface, press  to have access to data transfer mode, where two ways are provided : “Memory to U Disk” and “U Disk to Memory”



Functions:

No.	Description
A	Pattern List
B	Pages: the current page/total pages are displayed
C	 : Memory Pattern List  : U Disk Pattern List

D	Select All Patterns
E	Delete Pattern
F	Quit and Return to Upper Interface
G	Page Key
H	<p>Load pattern from memory or U disk</p> <p> : Activate the Memory Load Mode: At this moment, user cannot load pattern from U disk.</p> <p> : Deactivate the Memory Load Mode: At this moment, user can load pattern from U disk.</p> <p> : Activate the U Disk Load Mode: At this moment, user can not load pattern from memory.</p> <p> : Deactivate the U Disk Load Mode: At this moment, user can load pattern from memory.</p> <p> : Shift between U Disk and Memory</p>
I	Enter

Operation:

1、 Copy Mode Selection

The default setting is to copy pattern from memory to U disk, user can press  to change the copy mode.



2、 File Selection

Select the pattern for copy in the pattern list (here, we select No.400, 401 and 600). If the patterns are so many, please use  to turn the page.

For copying all the patterns, please press . For deletion, please press .

3、 Confirm the Copy



After selection, please press . Then the system will display “Copy the Selected Pattern”, user can press  to perform the operation. If the pattern is copied from memory to U disk, the system will automatically create a catalogue naming “dh_pat” at the base catalogue of U disk and save the pattern in that catalogue.

[Note]: At the process of copy, if the memory contains the pattern with the number same to that of the pattern in the U disk, the new pattern will replace the old one.

2.9.2 Formatting Mode

In function setting interface, press  to activate formatting Mode

There are formatting methods in this interface: USB formatting, Memory formatting, Self-defined formatting and Pattern number hotkey formatting



1、USB Formatting:

Press “USB” to delete all the patterns within the U disk. So user needs back up the data if necessary.

2、Memory Formatting:

Press “Memory” to delete all the patterns within the memory.

[Note]: After the memory formatting, pressing  will have system display “Not Find

Pattern in Memory”. Pressing  will automatically load the default patterns.

3、Self-defined Formatting:

Press “Self-defined” to have access to the interface for Self-defined formatting

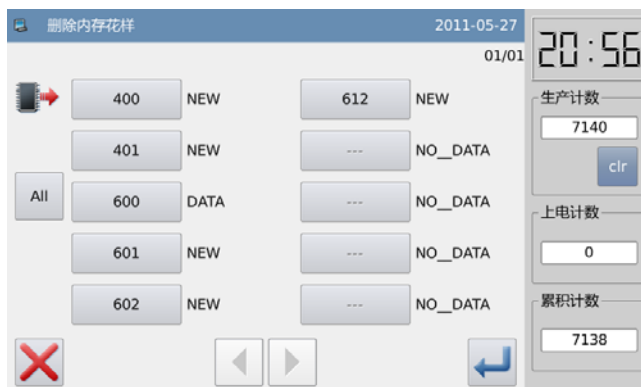

In that interface, the system will provide the entire patterns, where user can delete patterns by selection.

[Note]: The pattern being sewn can not be deleted.



4、Hotkey Formatting:

Pressing “Hotkey” to delete the content of the hotkeys of pattern number.

[Note]: After the hotkey formatting, pressing  will have system display “Pattern List (Hotkey) Is Empty”. Pressing  will automatically load the current pattern number to the hotkey.

2.9.3 Pattern Connection Mode

In function setting interface, press  to have access to Pattern Connection Mode. The pattern connection mode is mainly used to create and edit the combined pattern, which is to perform the combination edition on the basis of the existing patterns. The pattern used for consisting of combined pattern is called as sub-pattern

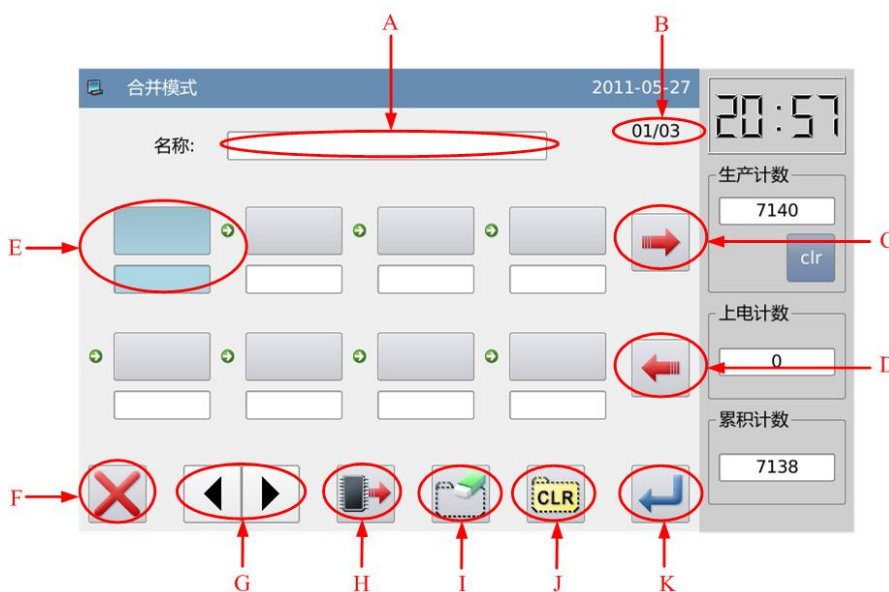

Function:

No.	Description
A	Name of Combined Pattern
B	Page
C	Load Combined Pattern
D	Save Combined Pattern
E	Display Sub-pattern
F	Quit & Return to Previous Interface
G	Page Key
H	Add Pattern from Memory to Combined Pattern
I	Delete Sub-pattern
J	Cancel Combined Pattern
K	Enter

Operation:

1、 Select a Sub-pattern

Press  to have access to Load Mode and select the pattern for adding (select pattern No.612 as an example).

Press  to confirm it.

[Note]: To add pattern to the combined pattern, user has to add them in order

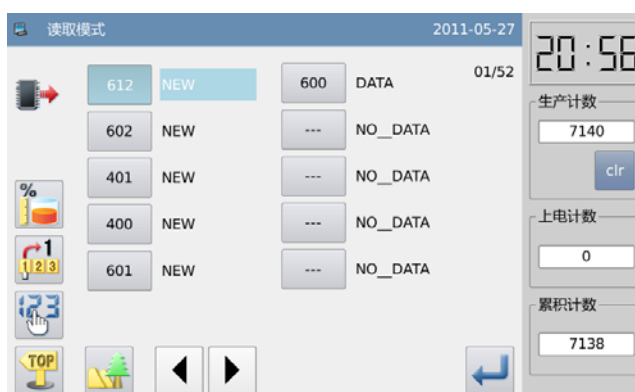

2、Continue Adding

Repeat the above operation to adding more sub-pattern (Add patterns No.600, No.602 and No.401)

If user wants to delete one of them, please select the number of the sub-pattern and then press .



3、Save the Combined Pattern

Press  to enter the mode for saving combined pattern

Name the combined pattern and press  to confirm it. For other operations within this interface, please refer to [2.6 Save Pattern].



4、Return to Main Interface

After edition of the combined pattern, press  to return to main interface.

As shown in right figure, there are some differences between the combined pattern sewing interface and the normal pattern sewing interface.



① The name of combined pattern is displayed behind the number and the name of the current sub-pattern will be displayed at the name area.

[Note]: If the combined pattern has no name, nothing will be displayed.

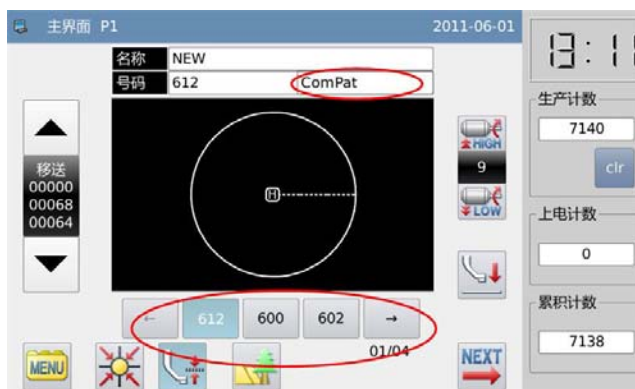
② The original pattern number hotkey are will display the sub-patterns in this combined pattern. Click the sub-pattern to start the sewing from that sub-pattern.





5、Cancel the Combined Pattern

In order to cancel the combined pattern, user has to enter the pattern connection mode again, presses  and clicks .



6、 Load Combined Pattern

In pattern connection mode, if user presses  when the combined pattern exists, the system will display “Clear Current Combined Pattern”.

Clicking  will clear the current combined pattern.

Press  again to have access to the interface for loading the combined pattern, where users need to select the combined pattern for sewing or editing.



2.9.4 Version Inquiry Mode

In function setting interface, press **Ver.** to have access to version inquiry mode.

Press  to output the software version to the base catalogue of the U disk with name “version.png”.



2.9.5 Display Setting Mode

In function setting interface, press  to have access to display setting mode, where user can perform the settings about the display, operation and so on.

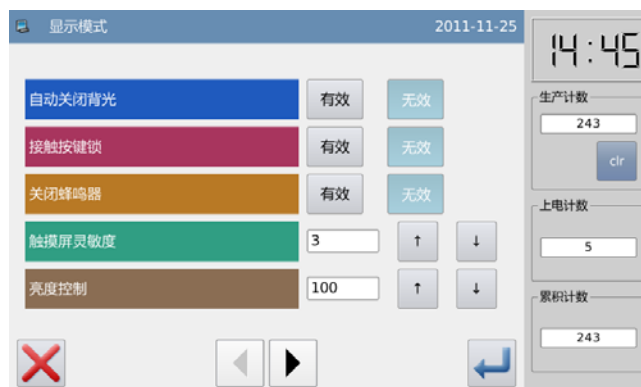

1、 Backlight Auto Turn-off

By the set time, the backlight of screen will be turned off automatically.

Range: 1~9 min

Default Value: Invalid

Releasing Method: If the backlight is off, user can touch any position on the panel to turn it on.

2、 Keyboard Lock

When it is set as “Valid”, all the buttons will turn to grey in display and become useless.

Pressing  will directly return to main interface P1.

Default Value: Invalid

Releasing Method: Hold the title bar at main interface P1 for over 5 seconds, until user hear “Bee--m”. After that the lock is released. (After the releasing, this function will be set as Invalid

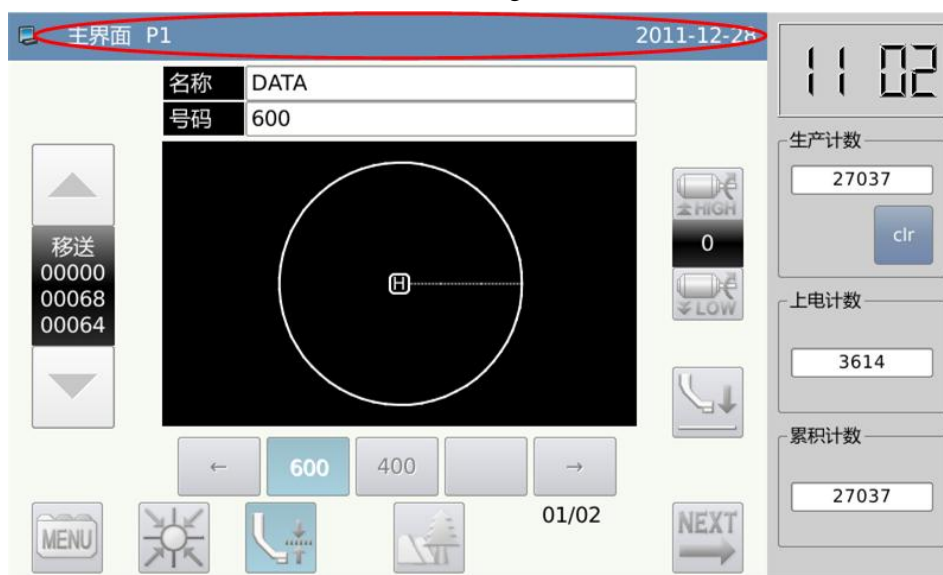

3、 Turn off Buzzer

When it is set as “Valid”, system will keep silence when user presses button.

Default Value: “Invalid”

4、Sensitivity of Touching Panel

Adjust the sensitivity of the touching panel. The larger value means the higher sensitivity

Range: 1~5

Default Value: 3

5、Lightness Control

Adjust the lightness of the LCD screen. The larger value is, the lighter will be

Range: 1~100

Default Value: 100

6、Button Display Style

Set the display style of some buttons. After the successful setting, the button display under interfaces of “Catalogue Mode”, “Test Mode” and “Function Setting” will be changed

Range: 0~1 (0: Icon, 1: Text)

Default Value: 0



Icon Style Display



Text Style Display

7、Background Color Setting

Set the background color of the pattern display area in main interface

Range: 0~6 (0:Black, 1: Dark Blue, 2: Red, 3: Green, 4: Blue, 5: Purple, 6: Yellow)

Default Value: 0

8、Display Style of Pattern Selection

Set the display style of the interface for loading patterns. Only the used patterns can be displayed.

Range: 0~1 (0: Number, 1: Shape)

Default Value: 0

Please refer to [2.5.5 Display Style of Pattern List]

9、Panel Display Style

Adjust the panel display style

Range: 0~2 (0: plastique, 1: cleanlooks, 2: windows)

Default Value: 0

10、 Pattern-making Style

Set the display style of the pattern-making operation interface

Range: 0~1 (0: Style 1, 1: Style 2)

Default Value: 0

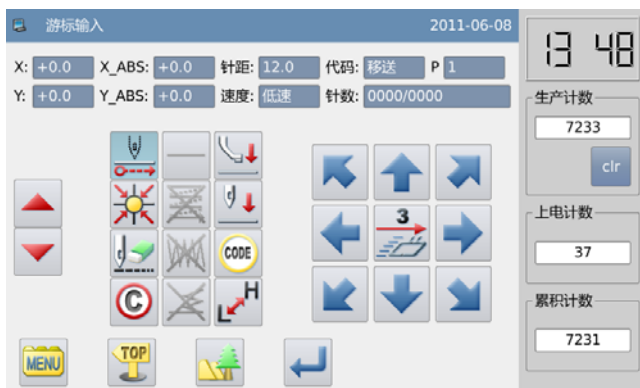

Style 1

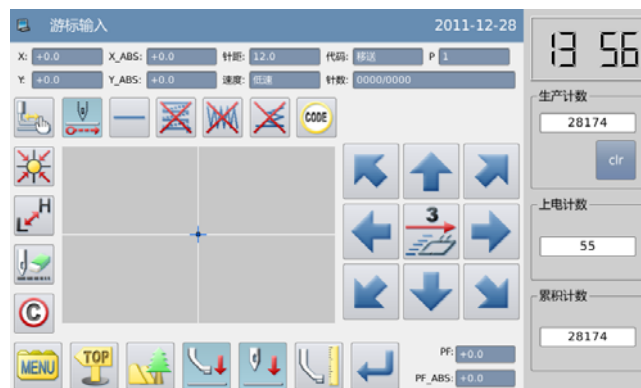

Style 2

11、 Position of Assistant Information Bar

Set the position of the assistant information bar

Range: 0~1 (0: Right, 1: Left)

Default Value: 0

[Note]: After the setting, user has to restart the system

12、 Main Interface Background Color

Set the background color of the main interface

Press “Setting” to open the color board.



Select the color and press “OK” to confirm and turnoff the color board

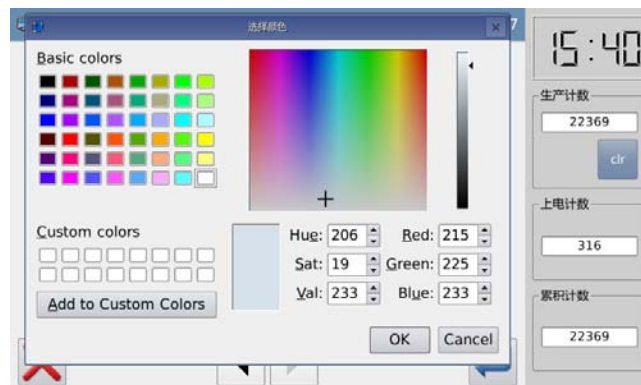

At this time, the color display area will show the selected color. Press  to return to the main interface P1 directly and change the background color of the main interface.



13、 Background Color of Assistant Information

Set the background color of assistant information bar. The operation is same as above.

2.9.6 Back-up Recovery Mode

In function setting interface, press  to have access to back-up recovery mode.

User can save the value of changed parameter into the U disk for the parameter recovery in future.

For details, please refer to [2.7.4 Recovery and Back-up of Parameter]



2.9.7 Default Parameter Mode

In function setting interface, press  to input the password (the original password is the manufacturer ID). After the input of password, the system will have access to Default Parameter Mode.

It is used to recover the default parameters and to save the parameter values for future.

Please refer to [2.7.5 Default Parameter Recovery] for details



2.9.8 Pattern Hotkey Management Mode

In function setting interface, press



to have access to Parameter Hotkey Management Mode, where user can edit the pattern number hotkeys.



1、Input Pattern Number and Select the Position of Hotkey for Editing

Please refer to [2.5.1 Direct Load Mode]. User can input the number to find the pattern, if he knows that number.

Then select the position of edition in the hotkey display area (We select the third blank)



2、Edit the Hotkey

Select a pattern number in the pattern list, then that number will be displayed at the position that we selected in the previous operation.

User can also add the pattern at the position that already has a pattern in the hotkey list. This is to insert a number at this position. The numbers after will be moved correspondingly.

[Note]: If the pattern number for adding has already existed in the hotkeys, the system will adjust its position to the location that is closest to the selected position



3、 Deletion and Formatting

Select a pattern number in the hotkey display area and press  to delete that number. Then the system will automatically adjust the number position in the hotkey list.

Press  to delete all the number in the list.

[Note]: After the hotkey formatting, pressing  will have system display “Pattern List (Hotkey) Is Empty”. After confirming the operation the system will automatically load the current pattern number to the hotkey.



2.9.9 Password Mode

In function setting interface, press  to activate the interface for inputting the user ID. Input the correct manufacturer ID to have access to the password management mode, where is used to set and manage the periodical password.

① At most 10 different password action times can be set.

② System can display the password information of the manufacturer.



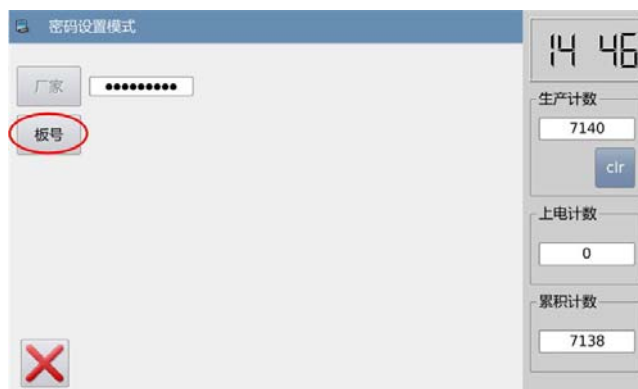

1、Input Board Number

Press “Board Number” to enter the interface for inputting the board number. The board is formed by four figures, the range is from 0000 to 9999. This can be used for the management of the password by the manufacturer. After inputting the board number, user can press  to finish the operation and return to the previous interface. (At here, we input 0001 as the board number).



2、Confirm the System Clock

Press “Clock” to have access to the interface for setting system time and date. For changing the system clock, user needs press  after the modification (Refer to [2.9.14 Date and Time Setting Mode]), or press  to quit.

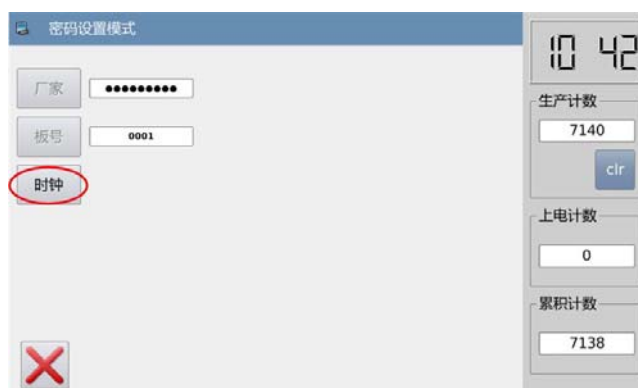

3、 Input the Super Password

Input “Super Password” to have access to the interface for inputting the super password.

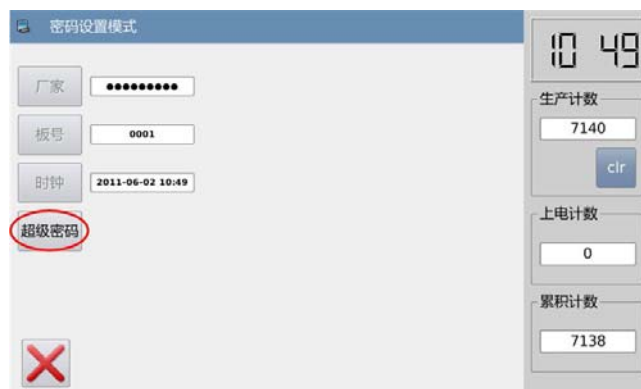

At most 9 figures can be inputted, which are displayed as “•”. After user presses , the system will ask user to input that password again for confirmation.

If the inputted passwords in these two times are different, the system will ask user to input the super password again. After these two inputted passwords are

same, user can press  to save it and quit.



4、Input Activation Time and Periodical Password

Input “密码-1” to input the first activation date.

The activation date is the first time that the password is activated. This date shall be later than the system date.

Select the proper date and press  to finish the operation. At this moment, the system will turn to password input interface

The input method of the periodical password is same as that of the super password. After the confirmation, user needs press  to quit.



5、Continue Inputting Periodical Password

If user needs input the next activation date and password, he should repeat the operation at above. At most, ten dates and passwords can be inputted.

[Note]: The next date shall be later than the previous one.



6、 Save Password

Input the needed password, and then press  to save the entire information. The system will display “Password Saved Successful”.

After confirmation, the system will return to the previous interface.

[Note]: Only when user set one periodical password, can  be displayed.

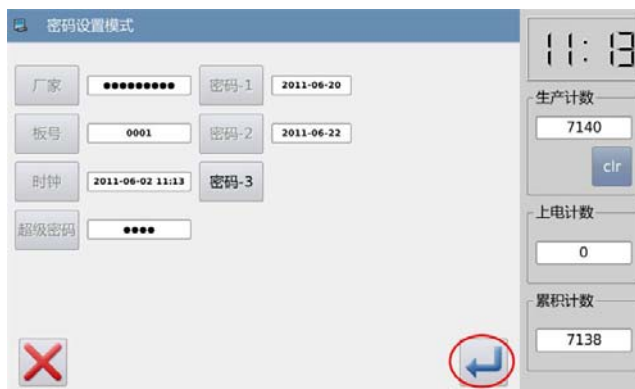

7、 Clear Password before Activation

Clearing password is to delete the password before it activates.

The method for entering the password display interface is same as that of entering the password setting interface

After user input the right manufacturer ID, the system will display the current time and activation dates of periodical passwords, as shown in right figure

Press  to input the current password. The password is cleared in order of from front to behind.

At this moment, user can input two passwords. If the inputted password is the current password, the current password will be deleted. If the super password is inputted, the entire password will be deleted. If the current password is deleted and the current password is the last password, the system will have no password any

more. Press  to finish the operation.

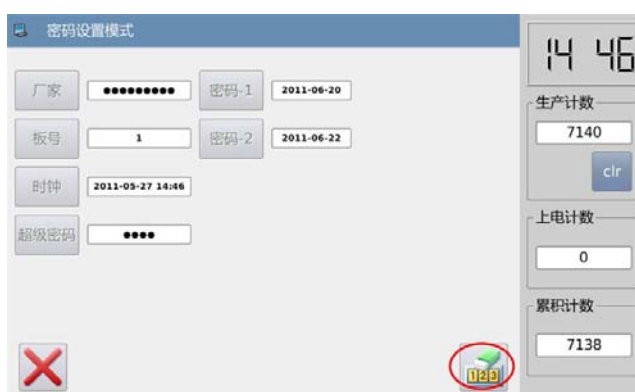

The deactivated password is displayed in red, as shown in right. If all the passwords are deactivated, the system will automatically return to the previous level.

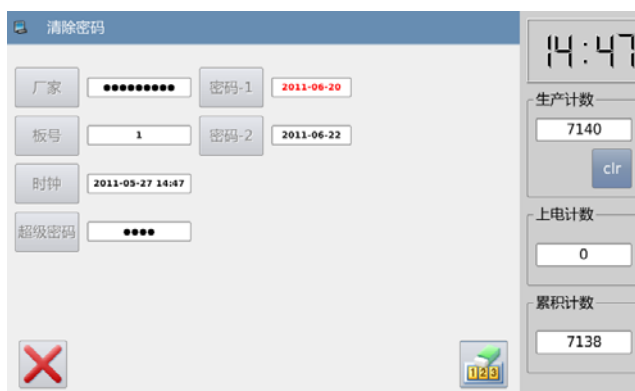



8、Clear Password at Activation

If the system has the password and that password is not canceled, the password will activate at the set date. At this moment, user has to input the effective password to have the machine to work normally.

The effective passwords include the current password and the super password. If the inputted password is the current password, the current password will be deleted. If the super password is inputted, the entire password will be deleted. If the password is current password and the current password is the last password, the system will have no password any more. If the machine still have other password other than the current password, the next password will activate according to the set date



2.9.10 Parameter Encryption Mode

In function setting interface, press  , then system will ask for the password (default password is manufacturer ID). Input the right password to have access to the parameter encryption interface.

For details, please refer to [2.7.3 Parameter Encryption]



2.9.11 Motor Configuration Mode

In function setting interface, press , then system will ask for the password (default password is manufacturer ID). Input the right password to have access to the motor configuration interface.



Example:



Press the “Main Motor” to have access to the main motor configuration parameter interface.

We can see all the parameters are displayed in forms. Clicking any form will display the arrow for adjusting the parameter value. No arrow means the parameter can not be set.

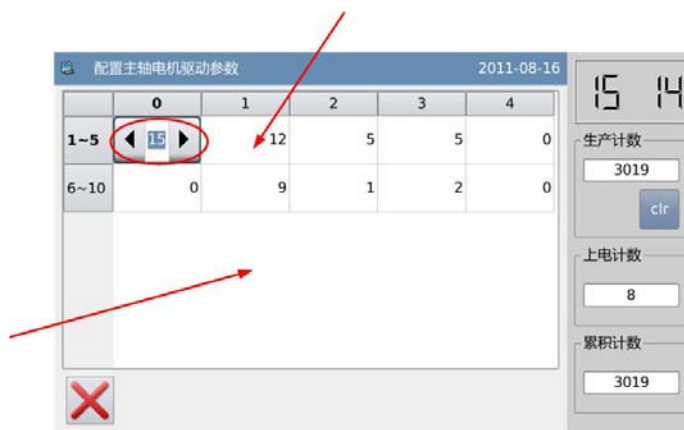
Set the parameter and then click the area beyond the grid to save that parameter value. (At here, we changed No.1 parameter. After the modification, we need click at the area pointed by arrow to save the value)



2.9.12 Alarm Record Mode



In function setting interface, press  , then system will ask for the manufacturer ID. After user gives the right ID, the system will have access to the alarm record mode

In this mode, the current alarm will be recorded. The smaller number means the later the alarm is.

It also records the accumulated production value at each alarm.



2.9.13 Running Records Mode

In function setting interface, press  , then system will ask for the manufacturer ID. After user gives the right ID, the system will have access to the running record mode.

① Accumulated Running Time: Record total sewing time of machine.

② Accumulated Sewing Pieces: Record the total number of the sewn patterns.

③ Accumulated Power-on Time: Record the total time of power-on

④ Accumulated Stitch Number: Record the total stitch number of the machine.

Additionally, click “Clear” to clear the counting value



[Note]: If the Accumulated Sewing Pieces is cleared, the system will also clear the Accumulated Counter in the assistant information bar at main interface

2.9.14 Date and Time Setting

In function setting interface, press



to have access to the date and time setting mode.





1、 Method for Setting Date

Click “Year” (At here, it is 2011.)to display two arrows to adjust it

Click “Month” (At here, it is June) to display the list of months. User can select the proper month.

After the setting, the display of year and month will be refreshed to the right ones.



User can also use  &  to check the content in calendar.

Click the day to complete the setting.

[Note]: User has to set year, month and date to finish the setting. Only setting the year and month will not complete this operation.

2、 Method for Setting Time

In default, user has to set hour firstly. Press “hour” to shift the setting to minute (Pressing “hour” is to change it to “minute”) and then press the arrows to change the time

User can also click the display area to shift between hour and minute.

After the setting of date and time,

please press  to save it.





3、Forbid to Change System Time

Once the machine is set the periodical passwords, the system will deny the change on the system time. After all the passwords are cleared, the system will unlock the setting of the system time.



2.9.15 Update Mode

In function setting interface, press  . The system will ask for the manufacturer ID. Input the correct ID to have access to the software update mode.

The updating software shall be located in the catalogue “Update” in U disk.

Click the content for update (the content in shadow is the selected), then

press .



2.10 Letter Sewing Edition

In main interface P1 (or P2), press



to activate the catalogue mode,

and then press  to have access to letter sewing edition mode.

[Note]: Parameter [Special] -> [Letter Sewing Function Enable] can be used to close the function of letter sewing edition. After that, this figure will not be displayed

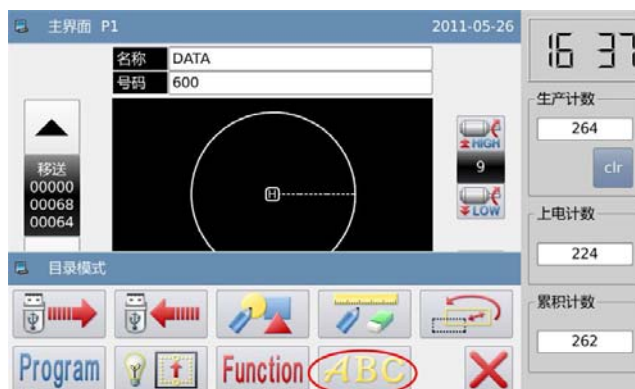

2.10.1 Parameters of Letter Sewing

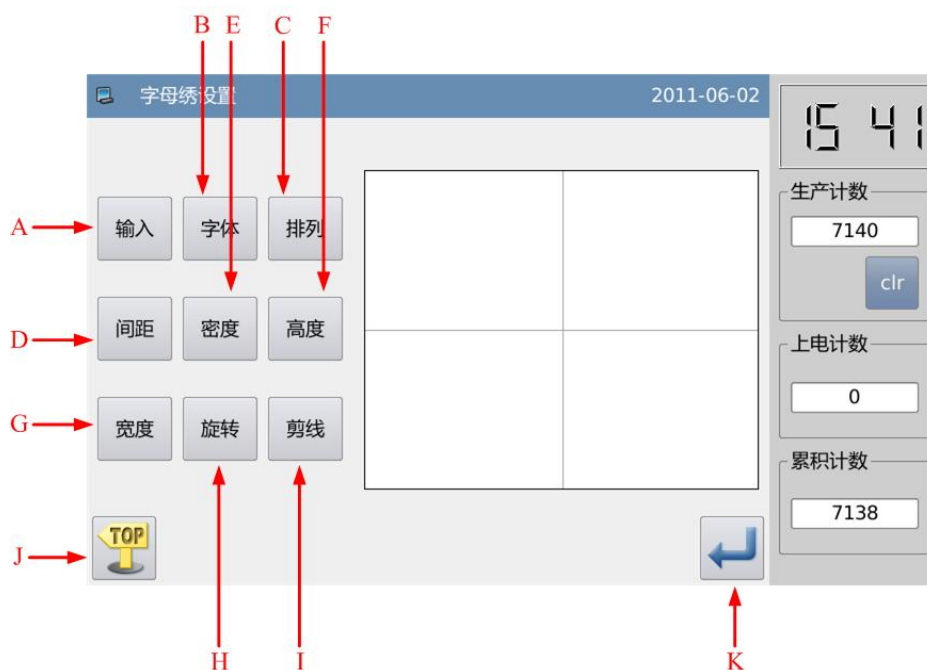

Functions:

No.	Functions	Content
A	Figure Input	Input figures. At most, 20 figures can be inputted
B	Font Selection	28 fonts are available.
C	Array Method	User can select "Horizontal", "Vertical", "Upper Arc" "Down Arc"
D	Letter Pitch	Set the interval between letters
E	Density of Satin	Set the satin density. The larger value means the denser satin stitches
F	Scaling in Height	Scale the height of letter, range: 50~200.
G	Scaling in Width	Scale the width of letter, range: 50~200.
H	Rotation/Follow (Not Follow)	When the array method is linear (vertical or horizontal), the content on the button will be displayed as "Rotation", which is to set the rotation angle of letter; When the array method is arc (Upper Arc or Down Arc), this button will display "Follow" or "Not Follow", which is to set whether the letter rotates with the arc.
I	Trim/Not Trim	Set whether to automatically insert thread-trimming code
J	Return	Quit and return to main interface
K	Enter	Confirm operations. And then enter pattern adjustment interface.

1、Figure input

Press “Input” to have access to figure input interface, where user have to input at least one figure. 20 figures can be inputted at most.

Press  to save the input and quit.



2、Font Selection

Press “Font” to have access to font selection interface, where 28 types of fonts are provided. Input the numbers from 1 to 28 to select the font. Press  to save it and quit.

In this interface, the font will be displayed to users.

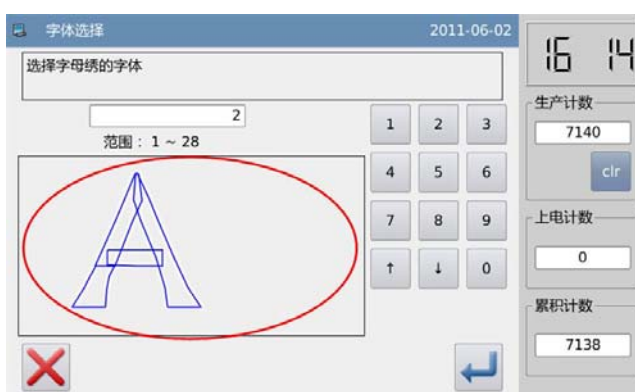

3、Array Method

Press “Array” to have access to the interface for setting array method, where user can select horizontal linear, vertical linear, upper arc and down arc. Press  to save it and quit.



4、Figure Pitch

Press “Pitch” to have access to the letter pitch setting interface.

In horizontal array, it is to set the horizontal pitch between letters.

In vertical array, it is to set the vertical pitch between letters.

In arc array, it is to set the distance between the letters on arc

Range: 0~99.9mm.



5、Density of Satin

Press “Density” to have access to the interface for setting satin density. The range is among 50~200.



6、Scaling in Height

Press “Height” to have access to the interface for setting letter height, where user can scale the height of letter. Range: 50~200.



7、Scaling in Width

Press “Width” to have access to the interface for setting letter width, where user can scale the width of letter. Range: 50~200.



8、Rotation Angle Setting

When the array method is set at “Horizontal” or “Vertical”, user can set the rotation angle of the letter. Press the “Rotation” to have access to the interface for setting rotation angle.

The rotating direction is counterclockwise. Range: 0°~359°.

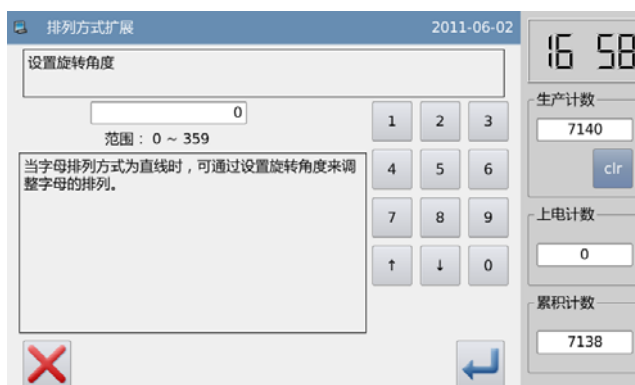

[Note]: When the array method is arc (Upper Arc or Down Arc), this button is to set whether the letter rotates with the arc.

9、 Follow/Not Follow

When the array method is arc (Upper Arc or Down Arc), user can set whether the letter rotates with the arc. Press “Follow” to shift it to “Not Follow”

[Note]: when the array method is “Horizontal” or “Vertical”, this button is to set the rotating angle.



10、 Add Auto-Trimming

In default setting, the system will add auto-trimming, which is to add trimming code at the end of sewing, joint of empty feeding (or sewing).

Press “Trim” to change the content on button and cancel the function for automatically adding trimming functions.



11、 Confirm the Pattern

Set the letter sewing pattern for generation. Press  to have access to the interface for adjusting the letter sewing pattern.



2.10.2 Adjustment of Letter Sewing Pattern

In the interface for setting letters of the letter sewing, user can press  to have access to the interface for adjusting the letter sewing pattern. In this interface, user can have the further adjustment on the pattern.

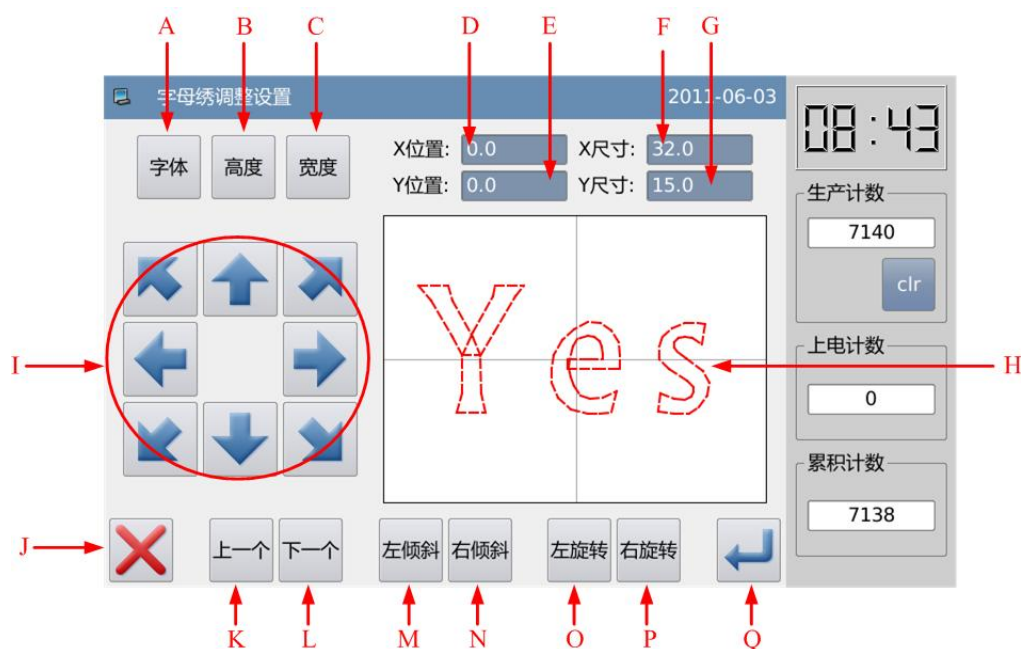

Functions:

No.	Functions	Content
A	Font Selection	Change the font of the selected letter. The setting method is same to that in Parameter Setting
B	Scale in Height	Scale the height of the selected letter. The setting method is same to that in Parameter Setting
C	Scale in Width	Scale the width of the selected letter. The setting method is same to that in Parameter Setting
D	X Position	Display the X coordinate of center point of the selected letter
E	Y Position	Display the Y coordinate of center point of the selected letter
F	X Size	Display the width of the selected letter
G	Y Size	Display the height of the selected letter
H	Pattern Display	Display the current pattern for letter sewing. The selected letters are displayed in red; the unselected letter is displayed in green.
I	Direction Key	Adjust the position of the selected letter.
J	Esc	Return to the previous interface
K	Previous Letter (from right to left)	Select the letter for adjustment from right to left. The selected figure is displayed in red. When the icon still goes to left at selecting the last letter, the entire letters will be selected
L	Next Letter (from left to right)	Select the letter for adjustment from left to right. The selected figure is displayed in red. When the icon still goes to right at selecting the last letter, the entire letters will be selected
M	Left Tilt/Radian Down	When the array method is horizontal array or the vertical array, this button will display “Left Tilt”. Pressing this button will rotate the entire pattern counterclockwise in the center of origin When the array method is arc, this button will display “Radian Down”. Pressing this button will reduce the radian of entire pattern.

		[Note] This operation is for the entire pattern.
N	Right Tilt/Radian Up	When the array method is horizontal array or the vertical array, this button will display “Right Tilt”. Pressing this button will rotate the entire pattern clockwise in the center of origin When the array method is arc, this button will display “Radian Up”. Pressing this button will increase the radian of entire pattern. [Note] This operation is for the entire pattern.
O	Left Rotation	Adjust the rotating angle of the selected letter counterclockwise. The rotation center is the center of the letter
P	Right Rotation	Adjust the rotating angle of the selected letter clockwise. The rotation center is the center of the letter
Q	Enter	Press it to have access to the pattern save interface

Example:

1、 Select Single Letter for Adjustment

Press “Previous Letter” or “Next Letter” to select the single letter for adjustment. The selected letter is displayed in red, while the unselected are displayed in green



2、 Letter Position Adjustment

Press the direction key to adjust the position of the selected letter. User can see the coordinates from “X Position” and “Y Position”

With the same operations, user can adjust the position of other letters.



3、Adjust the Rotating Angle of Entire Pattern

Press “Left Tilt” or “Right Tilt” to adjust the rotating angle of the entire pattern

“Left Tilt”: Counterclockwise

Rotation

“Right Tilt”: Clockwise Rotation

[Note]: When the array method is arc, these buttons will turn to “Radian Up”/ “Radian Down”, which are to adjust the radian of the entire pattern



4、Rotation of Single Letter

Select a letter and then press “Left Rotation” or “Right Rotation” to adjust the rotating angle of the selected letter

[Note] When adjusting the rotating angle, user had better adjust the rotating angle of the entire pattern at first. If user adjust the rotating angle of the single letter at first, the adjustment will be canceled when user rotates the entire pattern.



5、Save Pattern

After the adjustment,

press  to have access to interface for saving patterns.



Input name and number, and then press . The system will hint “Letter Sewing Pattern Saved Successfully”. (For other operations, please refer to [2.6 Save Pattern])

[Note]After the successful saving, the letter sewing pattern will not turn to current pattern automatically. User has to enter the pattern loading interface to select it.



3 Appendix 1

3.1 Warning Information List

Number	Name of Malfunction	Sub-information Content	Solution
E-001	Pedal not at normal position	Please adjust pedal position	
E-002	Machine is in emergency stop	Check the condition of emergency switch	Turn and release the emergency button. If the screen keep displaying this hint, please check the following way: 1、 Check the condition of emergency button. 2、 Check the connection between the emergency button and head transfer board. 3、 Check the connection between the X9 terminal on cable L433 and the head transfer board. Open cable L433 to seek breakage.
E-004	Main voltage is too low(300V)	Please turn off power and check system hardware	1、 Check if the AC power supply have abnormal fluctuation; Make sure there is no large power device that is turned on/off frequently; equip the voltage regulator. 2、 if the AC power supply is normal, the problem may be at the hardware. Please return the main control board for repair.
E-005	Main voltage is too high(300V)	No	
E-007	IPM is over-voltage or over- current	Please turn off power and check system hardware	1、 Make sure no short circuit at main motor; check if the value of each winding is equal and not 0; 2、 Check whether the output at U\ V\ W is shorted to earth or the 300V power supply, so as to judge the condition of IPM.
E-008	Voltage of assistant device (24V) is too high	Please turn off power and check system hardware	1、 Check if the peripheral solenoids and valves are shorted. 2、 Make sure the cores in both plugs on L478 cable are not shorted. Check whether the head transfer board is shorted to head at installation
E-009	Voltage of assistant device (24V) is too low	Please turn off power and check system hardware	1、 Check if the peripheral solenoids and valves are damaged 2、 Check whether cores in both plugs on L478 (For Hai Ling, it is L432) cable are shorted. 3、 Check whether the head transfer board is shorted to head at installation. 4、 Check the power part at the main control board; check the pin on CPU for collecting 24V power signal
E-010	Valve (Fan) has	Please turn off power and	1、 Check whether the power of fan has

Number	Name of Malfunction	Sub-information Content	Solution
	problem	check system hardware	problem 2、 Check the condition of 24V for head board 3、 Search short connecting at peripheral valve
E-013	Encoder is error or unconnected.	Please turn off power and check system hardware	1、 Turn off the machine and check the connection between the encoder cable and the plug at control box.
E-014	Motor running abnormal	Please turn off power and check system hardware	1、 Check whether the main shaft is blocked by the load. 2、 Turn the hand wheel and repower the machine when the main shaft is at another angle. 3、 Motor reply signal error, replace motor
E-015	Exceeds sewing area	Please press Enter.	1、 Pattern data process is abnormal. Re-pick the pattern and search the origin for sewing again. Make sure the problem is at pattern or caused by BUG in software. 2、 Check whether the sewing range set in operation head matches to the selected pattern.
E-016	Needle rod Upper position abnormal	Please press Enter.	Turn the hand wheel to lift the needle rod to the upper position of the upper dead point, and then step the pedal.
E-017	Thread breakage detection error	Please press Enter.	Check CZ424 port on head transfer board and cable L433
E-018	Trimmer position abnormal	Please turn off power.	
E-019	Emergency switch is not at the right position	Check the condition of emergency switch	1、 It is common hint, not the problem. Please release the emergency switch. 2、 Refer to the solution in EB002
E-020	Stepping software version error	Please turn off power.	
E-023	Thread-catching position abnormal	Please turn off power.	
E-024	Wrong connection between operation head and sewing machine	Please turn off power.	
E-025	X origin detection abnormal	Please turn off power.	1、 Use debugging function to move the frame manually and test whether the coupler signal is displayed; 2、 When the machine is on, user can use a piece of metal sheet to approach the proximity switch. This is to test whether the system can give the vocal warning. 3、 Adjust the installation position of the proximity switch to ensure its reliable
E-026	Y origin detection abnormal	Please turn off power.	
E-027	Presser origin detection abnormal	Please turn off power.	
E-028	Thread-catching origin	Please turn off power.	

Number	Name of Malfunction	Sub-information Content	Solution
	detection abnormal		actions.
E-029	Intermediate presser origin detection abnormal	Please turn off power.	4、 Test the working condition of the stepping motor and make sure they have no step missed; 5、 Test the conditions of the stepping cables and sensor cables 6、 Check the connection of L433 cable, make sure this cable has no short or breakage at the connectors at both ends
E-030	Stepping driver communication abnormal	Please turn off power.	1、 Check the connection of cable between the main control board and the stepping board 2、 Make sure the stepping board power is normal or not. Ensure the power indicator and the working indicator are sparking normally
E-031	Stepping motor over-current	Please turn off power.	1、 The stepping motor is broken; user needs to replace the stepping motor 2、 the stepping drive board is broken; user needs to replace the stepping drive board
E-032	Stepping driver power abnormal	Please turn off power.	
E-034	Abnormal current	Please turn off power.	1、 Turn off the power. Turn the hand wheel to test the running of the main shaft. Check whether any mechanism is blocked.
E-035	IPM over current frequently 1	Please turn off power.	
E-036	IPM over current frequently 2	Please turn off power.	2、 Turn off the power. Check the connection at the coupling of the main shaft motor. The large interval at the coupling will cause the over-current at the motor 3、 Turn off the power. Measure whether the resistance values at the three-phase resistance are equal. If not, the motor is down. 4、 Turn off the power. Use the multimeter to test the IPM module, if IPM is down, please do not repower the machine. User needs to replace or repair it. 5、 When the system gives warning, please make sure whether the machine is at the process of trimming or stop. If so, please adjust the main shaft parameters to solve this problem.
E-037	Motor is blocked 1	Please turn off power.	1、 Due to the wrong location of the main shaft angle, the trimmer is jammed on the needle when cutting the thread, thus causes the main shaft to be blocked. Solution: Relocate the main shaft angle 2、 The needle rod is jammed on the intermediate presser at moving, which causes the blockage of the main shaft.

Number	Name of Malfunction	Sub-information Content	Solution
			<p>Solution: check the action of the intermediate presser and the connection between the air valve and the solenoid valve.</p> <p>3、 The trimmer can't cut the thread due to lacking of strength, which causes the blockage of the main shaft. Solution: adjust the main shaft parameter and increase the strength of trimming.</p> <p>4、 The mechanism has dead point, so the main shaft is blocked. Solution: adjust the mechanism;</p> <p>5、 The encoder at the main shaft motor has problem, which responses the wrong signal, thus causes the blockage of the motor. Solution: replace the main shaft motor</p>
E-038	Motor is blocked 2	Please turn off power。	<p>1、 The used fabric is too thick to be penetrated by the needle. Solution: adjust the main shaft parameters or change to a motor with larger power capacity;</p> <p>2、 The needle rod is jammed on the intermediate presser at moving, which causes the blockage of the main shaft. Solution: check the action of the intermediate presser and the connection between the air valve and the solenoid valve</p> <p>3、 The mechanism has dead point, so the main shaft is blocked. Solution: adjust the mechanism</p> <p>4、 The encoder at the main shaft motor has problem, which responses the wrong signal, thus causes the blockage of the motor. Solution: replace the main shaft motor</p>
E-039	Motor over speed	Please turn off power。	
E-040	Over current in stop status	Please turn off power。	
E-041	Motor overload	Please turn off power。	
E-042	Bus voltage abnormal	Please turn off power。	
E-043	X stepping motor position error	Please turn off power。	
E-044	Y stepping motor position error	Please turn off power。	
EB045	Presser not down	Step the pedal	
EB046	Not at origin cannot operate	Press key to return to origin	

3.2 Hint Information List

No.	Name	Content of Sub-information
M-001	Up counter reaches set value	Press Enter
M-002	Down counter reaches set value	Press Enter
M-003	Not at origin, cannot operate	Return to origin firstly
M-004	Pattern data not exist	Please reload or input again
M-005	Set value is too large	Please input value within valid range
M-006	Set value is too small	Please input value within valid range
M-007	Please press "Return to Origin"	
M-008	Save parameter abnormal	Press Enter to restore the default values
M-009	Cannot find pattern in memory	Press Enter to load the default patterns
M-010	Memory full	Please delete the idle sewing data
M-011	Delete pattern data from memory?	No
M-012	Replace pattern data in memory?	No
M-013	Can not delete pattern data.	The selected sewing data is being used
M-014	Format memory?	All the patterns within the memory will be deleted
M-015	Communication error	Abnormal event occurs in the communication between the operation head and the control box. Please turn off power and check it
M-016	Beyond sewing range	Make sure pattern data is in sewing range
M-017	Fail to load letter sewing file	No
M-018	Operation head not match to machine type	Please check the model and the software version
M-019	Low memory	Please delete the unused pattern data
M-020	Wrong pattern number	Please input the right pattern number
M-021	Beyond max stitch interval	No
M-022	Wrong password	Please input password again
M-023	Hardware clock error	The hardware clock has problem, please contact manufacturer for repair.
M-024	Stitch number beyond range	Please reduce stitch number
M-025	Inputted stitch interval is too low	Please input value within valid range
M-026	Inputted stitch interval is too low	Please input value within valid range
M-027	Offset origin existed	User can only input one offset origin.
M-028	Fast move is set too much or little	Please input value within valid range
M-029	Please press Return to Origin	No
M-030	Copy the pointed pattern?	No
M-031	Copy all pattern data?	No
M-032	Restore to default setting?	No

No.	Name	Content of Sub-information
M-033	USB is pulled out	U Disk Is Pulled Out !
M-034	Cannot find pattern data in U disk	No
M-035	At least input one letter	At making pattern of letter sewing, user has to input at least one letter
M-036	No alarm record	
M-037	Replace needle	Reach set value for needle replacement, please replace needle!
M-038	Replace oil	Reach set value for oil replacement, please replace oil!
M-039	Clean machine	Reach set value for cleaning machine, please clean machine!
M-040	Different data format	Please confirm the data format
M-041	Cannot create curve	Please input again according to the standards of curve input.
M-042	Cannot insert trimming at current position	Please add trimming behind sewing data
M-043	Cannot add same function code in one position	
M-044	Cannot insert offset origin at current position	Please add offset origin after feeding
M-045	Cannot create arc or circle at the inputted point	Please input again
M-046	Cannot create overlapped sewing data	Please add overlapped sewing after close shape
M-047	Cannot insert trimming after down pause	No
M-048	Cannot insert down pause before trimming	No
M-049	Not find offset sewing data	Function of offset sewing data transfer is unavailable
M-050	Not find multi-sewing data	Function of multi-sewing data transfer is unavailable
M-051	Select wrong position	No
M-052	Cannot scale	No
M-053	Distance over 12.7mm	No
M-054	Wrong pattern data	No
M-055	Create arc?	No
M-056	Create circle?	No
M-057	Create curve?	No
M-058	Create polygon?	No
M-059	Presser is not down	Please step pedal
M-060	Wrong User ID	Please input again
M-061	Fail to conform password	Please input password again
M-062	Cannot change system time	The periodical password is set. Can not change system time.
M-063	Fail to save password file	No
M-064	Fail to load password file	No
M-065	Password saved successfully	No

No.	Name	Content of Sub-information
M-066	Fail to clear all passwords	Cannot delete password file
M-067	Fail to clear password	After the password is cleared, the file input becomes abnormal
M-068	Password file is deleted without authorization	Periodical password is deleted without authorization, please turn off machine
M-069	User ID file damage	
M-70	Input pattern name	Please input pattern name no more than 8 figures
M-71	Please clear current combination data	Press "CLR" to delete current combination pattern
M-72	Empty input invalid	Can not input empty password
M-73	Password not match	Current password is wrong
M-74	New password is different.	New password is different from the retry password
M-75	Touching panel correction successful	Correction is successful. Please turn off power to restart.
M-76	Clear alarm records?	Yes: Enter No: X
M-77	Delete the selected file?	Yes: Enter No: X
M-78	Copy all patterns	Cover the original patterns? Yes: Enter No: X
M-79	Fail to copy file	Please check the space in memory
M-80	Fail to copy file	Please check if the USB disk is pulled!
M-81	Fail to open file	Fail to open file
M-82	Format not match	Formats don't match, current load denied
M-83	Parameter over range	Parameter is over range. After confirmation, the parameter over range will be restored according to the default parameters!
M-84	Please create catalogue and file	Please create catalogue bakParam in U disk. Name the back-up file as backup.param and copy it to bakParam catalogue!
M-85	File I/O error	File I/O error
M-86	Please select file	Select the file for input/ output
M-87	File not exist	Cannot find the corresponding file
M-88	Not input move amount	Please input move amount
M-89	Enter touching panel correction mode?	Yes: Enter No: X
M-90	Clear accumulated running time?	Yes: Enter No: X
M-91	Clear accumulated sewing pieces?	Yes: Enter No: X
M-92	Clear accumulated power-on time?	Yes: Enter No: X
M-93	Clear accumulated stitch numbers?	Yes: Enter No: X
M-94	Periodical passwords can't be same to super password	Please input password again

No.	Name	Content of Sub-information
M-95	Cannot change up counter (NUP)	At change, please turn off setting (NUP)
M-96	Cannot change down counter (NDP)	At change, please turn off setting (NUP)
M-97	Pattern list (hotkey) is empty	If the pattern list is empty, the system will automatically input the current pattern to list
M-98	Not select update item	Please select item for updating. At least select one item
M-99	Some selected update items don't exist.	The item not existing will be cancelled after return. For updating the rest items, please confirm again
M-100	Update successful	Update is successful, please restart machine.
M-101	Format U Disk?	Press Enter to perform formatting operation. Press Esc to quit current operation. \n After formatting, all pattern files will be deleted.
M-102	Can not find U disk	Please insert the U disk for formatting.
M-103	Successful	Current operation is successful!
M-104	Failed	Current operation is failed!
M-105	Format pattern list (hotkey)?	Press Enter to perform formatting operation. Press Esc to quit current operation
M-106	Cover the pattern with same name in U disk?	Press Enter to cover files. Press Esc to quit current operation
M-107	Fail to correct touching panel	Please perform correction again
M-108	Letter sewing pattern saved successfully	Please enter pattern loading interface to select newly created letter sewing pattern
M-109	The selected pattern is not normal format, please transfer.	Press Enter to perform transferring operation. Press Esc to quit current operation
M-110	Cannot transfer this pattern	Please confirm pattern
M-111	Restore all the settings?	Yes: Enter No: X
M-112	Restore the selected item?	Yes: Enter No: X
M-113	Not select item	Please select one or more parameters
M-114	SRAM initialization	Clear all data in SRAM. Please turn off power and restore the setting of DIP switch.
M-115	Cannot copy and cover current pattern	Current pattern number in copy group, system cannot cover it.
M-116	Need transfer pattern format	After transferring, user can preview the pattern
M-117	Cannot perform operation to combined pattern	Please enter pattern connection mode,

No.	Name	Content of Sub-information
		press "CLR" to cancel the combined pattern
M-118	Delete original pattern?	Delete original pattern after format transferring? Yes: Enter No: X
M-119	Intermediate presser in down position	Please lift intermediate presser
M-120	Turn off machine, Bye	No
M-121	Format of pattern with 20mm stitch interval	Not support this pattern format in this system
M-122	Wrong transferred pattern format	Please confirm pattern
M-123	Transferred pattern data is too long	Please confirm pattern
M-124	Cannot open transferred pattern	Please confirm pattern
M-125	Wrong accuracy of transferred pattern	Please confirm pattern
M-126	Parameter recovery successful	Parameter recovery is successful, please restart machine
M-127	Software version saving successful	Software version is saved to the base catalogue of U disk successfully

4 Appendix 2

4.1 Installation Size of Control Box

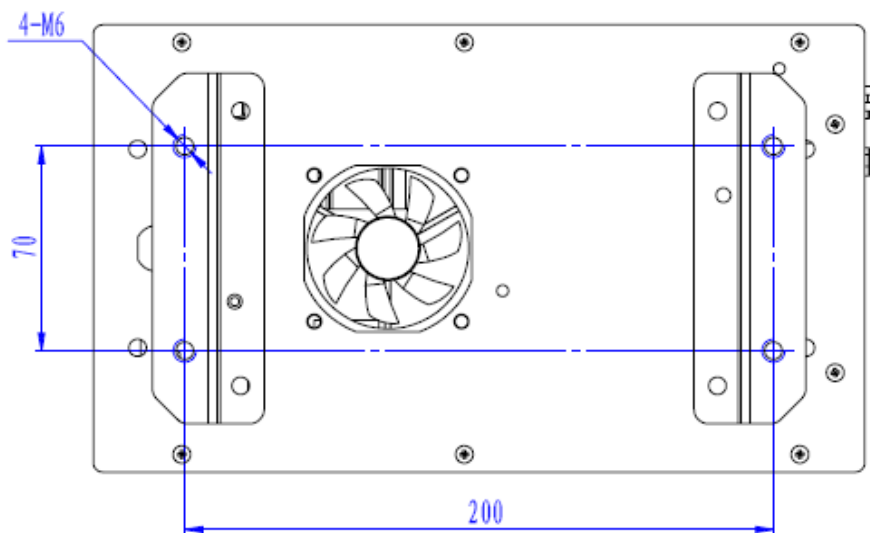

Figure 1 Installation Size (4 Holes)

4.2 Installation Size of Touching Panel

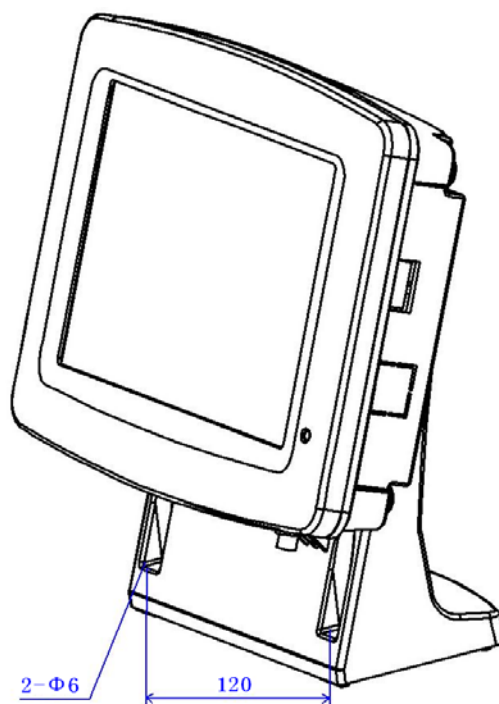
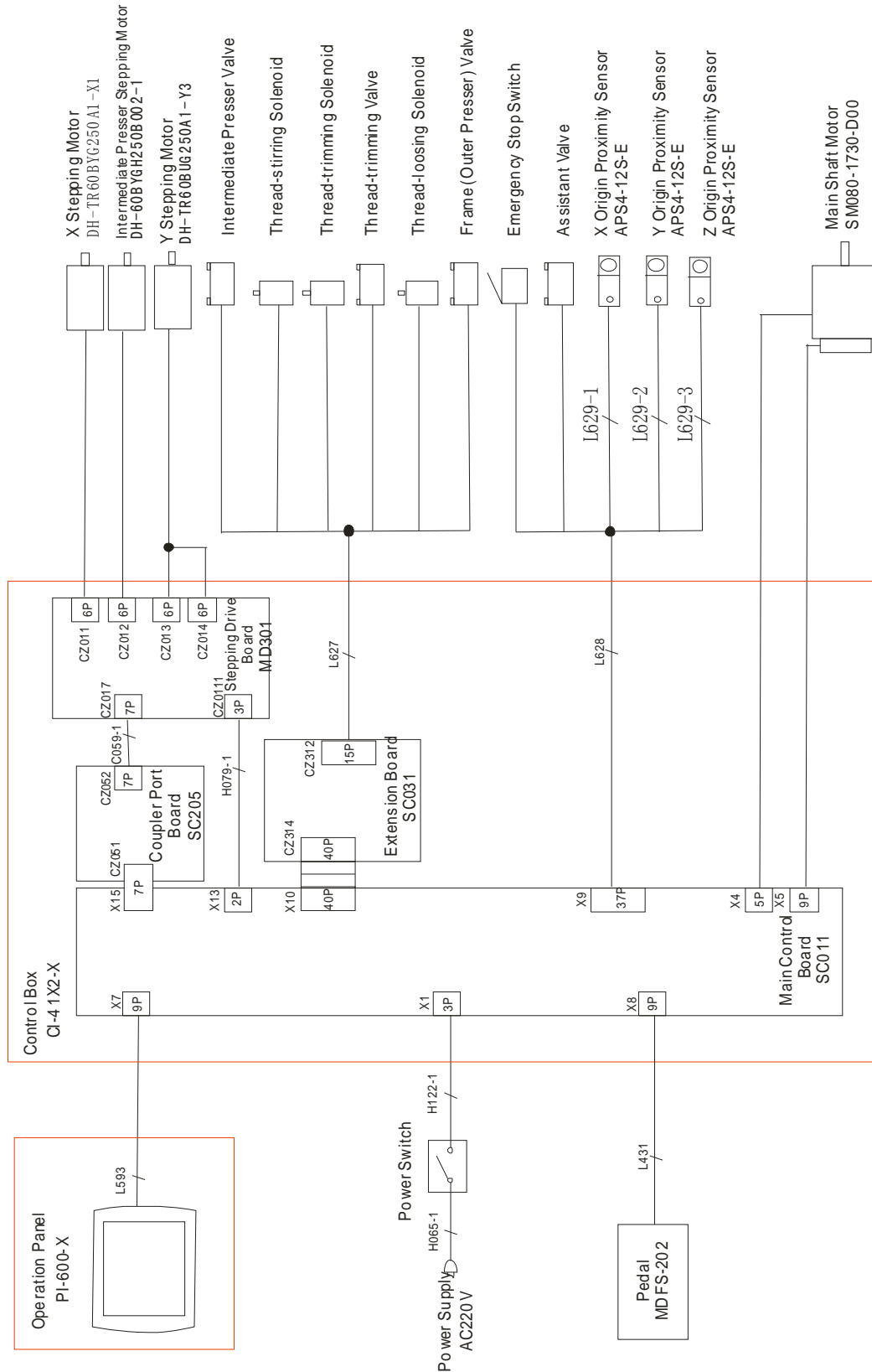

Figure 2 Installation Size of Touching Panel

4.3 SC41X Diagram and Cable Connection

4.3.1 SC411 Diagram



4.3.2 SC412 Diagram

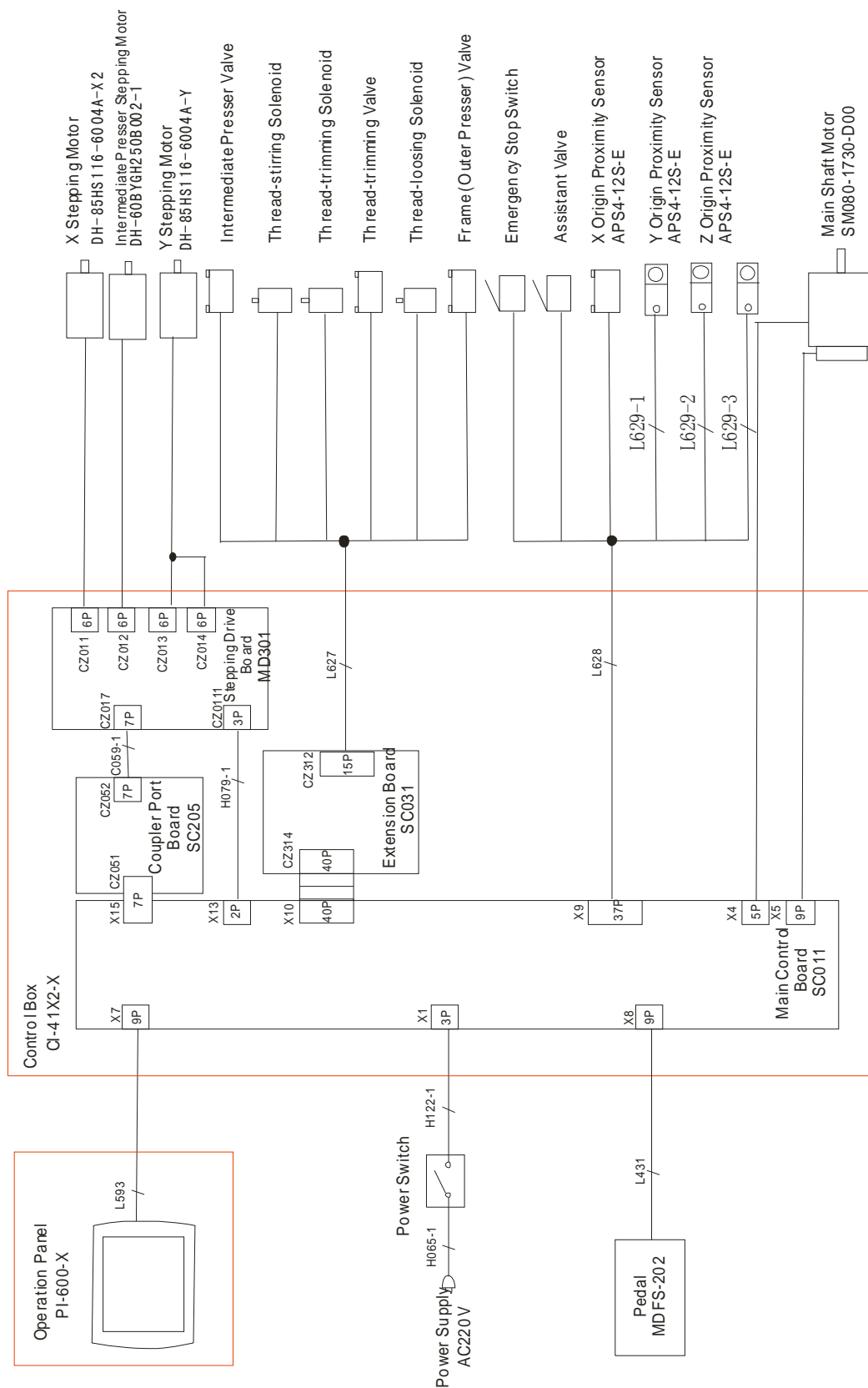

4.3.3 SC41X Cable Connection

Socket	Functions	Pin definitions
L627 (white)	Outer presser valve	1+, 2-
L627 (yellow)	Intermediate presser valve	1+, 2-
L627 (blue)	Thread-trimming valve	1+, 2-
L627 (black)	Thread-string solenoid	1+, 2-
L627 (red)	Thread-loosing solenoid	1, 2
L627 (white)	Thread-trimming solenoid	1, 2
L628 (white)	Assistant valve	1+, 2-
L628 (yellow)	Pause switch	1, 2
L628 (black)	Assistant Value	1, 2
L629-1 (white)	X origin sensor	1, 2, 3
L629-2 (yellow)	Y origin sensor	1, 2, 3
L629-3 (red)	Intermediate presser origin sensor	1, 2, 3